

the value of PBM valves



economic benefits of PBM Valves

visit PBM online @

www.pbmvalve.com



PBM valves offer value over the life of the product with:

- Fewer process interruptions
- Longer life
- Clean / drain without process interruption
- On-time delivery
- Improved product yields
- Documentation
- Unique solutions to problems

Fewer process interruptions

Adjust-O-Seal® feature

- PBM valves provide bidirectional upstream sealing. Seats are compressed tightly against the ball in the valve.
- Body bolts can be tightened to compensate for normal seat wear without having to remove the valve or interrupting the process.

PBM's Design

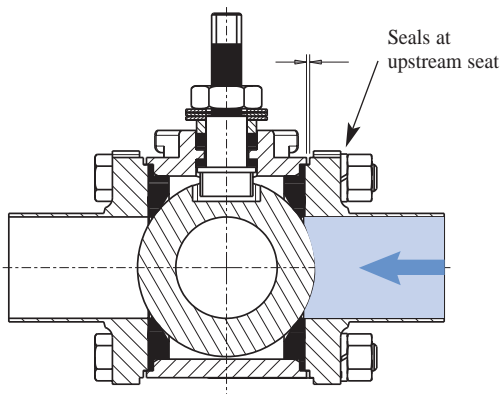

Valve body bolts compress valve seats against ball, providing bidirectional sealing at the upstream seat. To compensate for seat wear, body bolts can be slightly tightened to re-compress seats against ball.

Competitor's Design

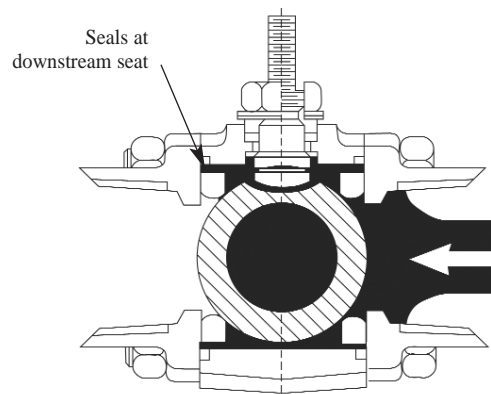

Line pressure pushes ball downstream in the ball-closed position, providing sealing at the downstream seat. There is no adjustment to compensate for seat wear.

MAINTENANCE REQUIRED

to repair a leaking valve

PBM

Slightly tighten valve body bolts to compress seats against ball to compensate for normal seat wear

Other valves

- Purchase replacement seats and seals (\$)
- Schedule maintenance time to replace seats (\$)
- Process downtime due to leaky valve (\$)
- Pay maintenance cost / time to remove/repair valve (\$)

Longer Life

PBM valves are designed and manufactured to last longer and perform better than other valves. You can adjust a PBM valve 4 to 6 times (before having to replace the seats) to compensate for normal seat wear.

Test Results

A PBM 1½-inch valve was tested against three other manufacturers' products. The valves were cycled under identical conditions until **seat, gasket, or stem packing leakage** was sufficient to necessitate removal of the valve for repair.

The PBM valve tested had a cycle life **over four times** that of Worcester, SVF, and the VanTek Taiwan Import valve.

	Worcester 11/2" WK7066TTTC
PBM SIHLG5X-G	SVF SB766666ATTR
	VanTek Taiwan Import

Clean / Drain valve without process interruption

There is another benefit of PBM's Adjust-O-Seal® feature that differentiates PBM from other ball valve manufacturers. Most ball valves rely on upstream pressure to force the ball to the downstream seat to seal. This is known as the "floating ball" principal. Look in their catalogs and you will see a diagram similar to the competitor diagram below.

COMPETITOR

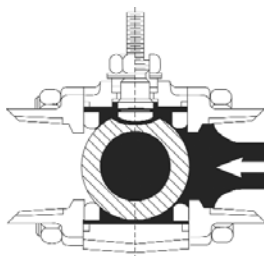

Line pressure pushes ball downstream in ball-closed position, providing seal at downstream seat. Body cavity contains media and pressure. Body cannot be drained or purged during process.

PBM'S DESIGN

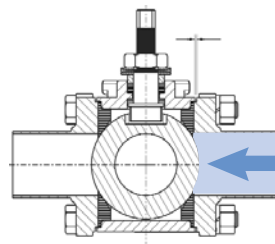

Valve body bolts force valve seats to ball, providing seal at upstream seat. Body cavity can be drained or purged during process.

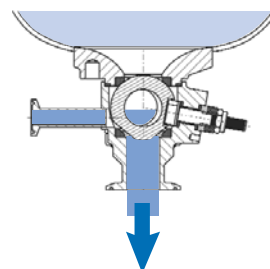

This means on valves mounted vertically, like the pictured PBM angle stem flush tank valve, the valve seats on the upstream seat, thus allowing the body to be purged and drained without process interruption.

On-time delivery

- PBM's goal is 100% on-time delivery
- "Stock" means Stock.
- Manufacturing, inventory and assembly at same location. Better control.
- Accurate delivery quotes

Have you ever been quoted "stock" from another valve manufacturer and finally receive the product in 2 or 4 weeks? "Stock" may mean 2 or 4 weeks to some manufacturers, but at PBM, we stake our reputation on "on-time" delivery.

PBM purchased competitive valves as an experiment in December 2002. The valves were quoted and ordered through authorized representatives of the respective manufacturer. We asked for identical products: 1.5 inch sanitary ball valve, sanitary Tri-Clamp ends, TFM™ / TFE seats, sanitary ID polish, manual operator, pad mount for automation.

The results are as follows:

Manufacturer	Manufacturer's Quoted Delivery	Actual Delivery
SVF	Stock	4 weeks
Worcester	4 weeks	8 weeks
PBM	Could have shipped same day if required	

Improved product yields

PBM offers valves to accommodate the same port diameter as the mating pipe. PBM offers *optional* True-Bore® for pipe valves with port diameters equal to the pipe schedule ID. This equates to a lot more flow rate compared to traditional port diameters!

Pipe / Tube Size	PBM's True-Bore® Port Diameter	Competitor's Port Diameter
4-inch Sch 40 Pipe	4.00 inches	4.00 inches (if full port)
4-inch Sch 10 Pipe	4.26 inches*	4.00 inches (if full port)
4-inch Sch 5 Pipe	4.33 inches*	4.00 inches (if full port)
4-inch Sanitary Tubing	3.87 inches	3.87 inches (if tube full port)

* Optional design

Documentation

PBM understands and provides documentation in accordance with specifications and purchase order requirements.

Examples of documentation that can be provided upon request:

- Material test reports: Mechanical Properties & Chemical Analysis of Materials of Construction
- CE marking and labeling
- Certification of compliance to customer's purchase order
- Hydrostatic test reports
- Export documentation and commercial invoices
- Provisioning technical documentation
- Engineering drawings and bill of materials, in electronic and CAD formats
- Compliance to FDA, USDA, ASME BPE, ANSI, USP, and others
- Installation, operation, and maintenance manuals

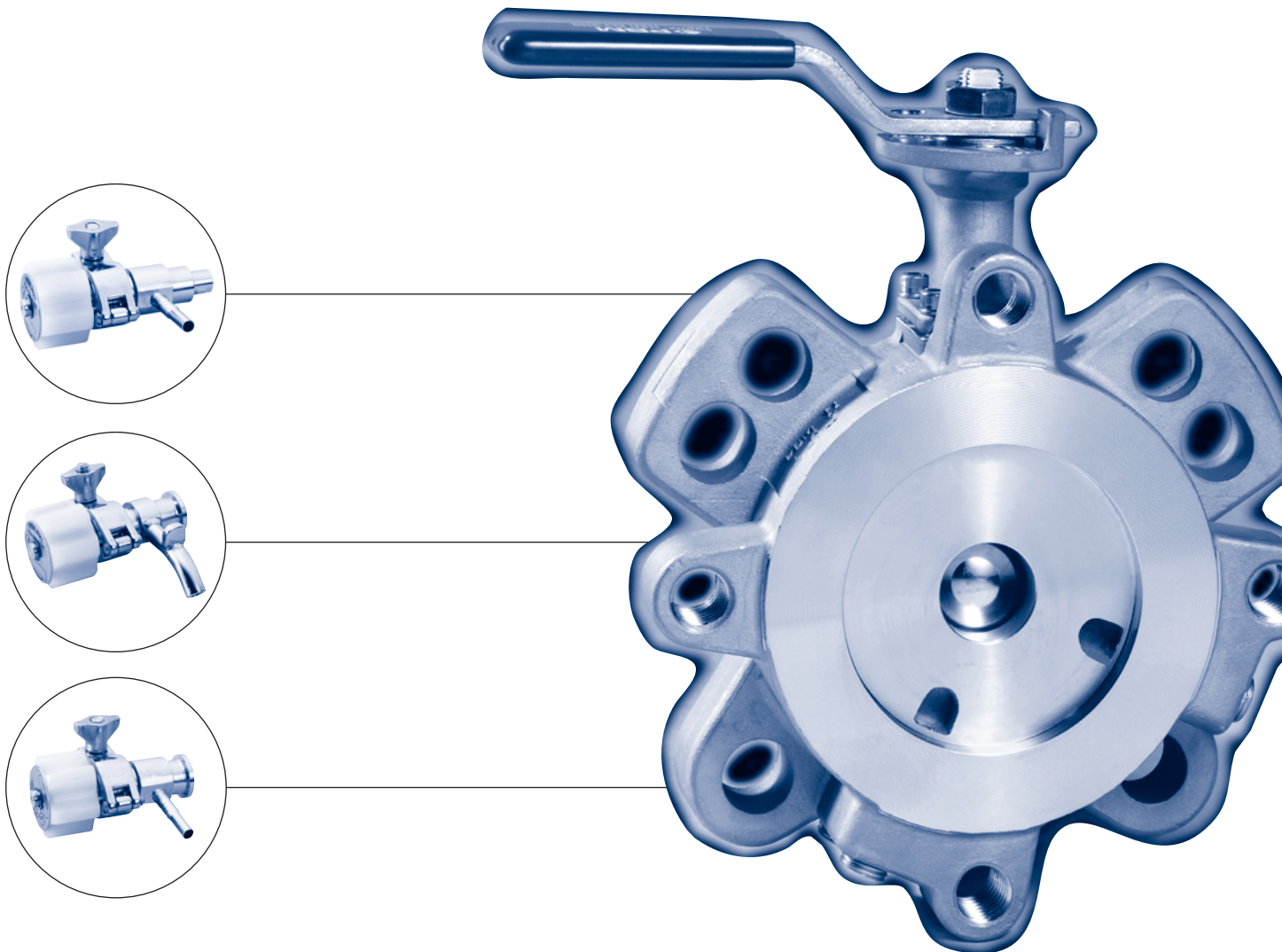

Unique solutions to problems

- Over 600 unique valve solutions per year
- Designs to specifically address an application or problem
- Designs to ANSI, DIN, SMS, and ISO dimensions and standards
- CAD drawings in any format submitted to customer in less than a week

5

Creative sourcing and manufacturing

- PBM rates all vendors on performance
- Cellular and “lean” manufacturing
- ISO 9001 certified
- Continuous improvement

Uncompromising Customer Service

- 24/7 emergency phone
- Project start-up assistance
- Field training and service
- World-wide representatives
- Experienced, trained, and readily available staff



PBM Innovations

PBM is an innovative leader and was the first to offer:

- Flush bottom tank valve
- True Multi-Port 4-seated ball valve
- Cavity fillers in ball valves
- Purge ports / flats for SIP/CIP in ball valves
- True Bore® tube / pipe diameter valves
- Direct Mount Actuation
- Clean steam ball valve with full encapsulated seats
- Valve designed specifically to accommodate thermal cycling
- Clean steam trap ball valve
- Fabflex® valve manifold assemblies

PBM continues to raise the bar to new heights with new innovative designs:

- Self-flushing ball valves
- Transmitter isolation valve with standard purge ports
- Angle stem flush tank ball valves
- Exotic alloy valves
- Rising stem sampling valves
- Integral V-Ball for flow control
- CIP / SIP valves without process interruption
- Cryogenic and higher temperature valves
- Innovative sanitary pipe and tube hangers and accessories
- Forged sanitary valves

PBM valves.
Quality valves at a great price.

visit PBM online @

www.pbmvalve.com

1.800.967.4PBM



ABOUT PBM

PBM offers a comprehensive product line for optimum performance in controlling and automating process lines. Our valves minimize contamination, comply with sanitary regulations, facilitate clean-in-place, solve clogging problems and reduce downtime. PBM's engineering and manufacturing teams will work with you to design special valve configurations.

Exceptional value, reliability and service that customers have relied on for over 100 years. You shouldn't expect anything less from a leading manufacturer of dependable, high quality valves. Call 800-967-4PBM to speak to a sales representative, or e-mail PBM with questions or a quote request at info@pbmvalve.com.



PBM, Inc.
1070 Sandy Hill Road ▪ Irwin, PA 15642
800-967-4PBM ▪ 724-863-0550 ▪ Fax: 724-864-9255
Email: info@pbmvalve.com ▪ www.pbmvalve.com

