

Installation, Operation, and Maintenance Instructions Radial Diaphragm Valves RD Series 1, 1/2" thru 4"



! WARNING:

For your safety and protection it is important that the following precautions be taken prior to working on the valve.

1. **Depressurize and drain the line.**
2. **Cycle the valve to relieve any pressure trapped in the valve.**
3. **Disconnect any air and electrical connections to the valve assembly, unless noted in these instructions.**
4. **Know what the media is in the line and wear appropriate protective clothing and equipment. Obtain appropriate MSDS sheets.**
5. **To ensure safe product selection and operation, it is the responsibility of the process system designer and end user to determine the appropriate compatible materials of construction and adequate product ratings for the process system. Process system designer, installer, and end user are responsible for proper installation, operation, and maintenance.**
6. **When disposing of Teflon parts, do not incinerate or subject to open flames.**
7. **WARNING: Valve clamp MUST not be opened during steaming or while valve is under pressure.**

1. General

This Installation, Operation, and Maintenance manual is for the safe use of PBM RD Series 1 radial diaphragm valves. Please read the instructions carefully and save them for future reference.

2. Installation

PBM Radial Diaphragm valves should be installed in the vertical position, under a tank/vessel. The inlet pads can be shipped in advance in order to weld/attach underneath a tank or vessel. Meanwhile, the valve can be shipped later and attached to the pad via hygienic clamp.

3. Operation

For manual valves, operation consists of turning the handle to close or open the valve. To open the valve, turn the handle counterclockwise and to close the valve turn the handle clockwise. These valves may also be automated with actuators and other valve automation equipment. The operator must be changed out if manual valves are converted to automated valves. For automated valves, operation is controlled by the actuator in place of the manual handle. Good operating procedure requires periodic inspection of the valves and replacement of parts as required. Always use PBM factory authorized replacement parts.

Diaphragm Wear / Removal of Diaphragm

Removal of the Diaphragm can be performed by following these steps:

1. Remove the main body from the pad by detaching the hygienic clamp. The hygienic gasket will also come off (If you only need to remove the diaphragm, proceed to step 2).
2. Using the proper spanner wrench, loosen and remove the coupling nut at the base of the body.
3. Pull the operator and diaphragm out of the body cavity.
4. Unthread the diaphragm (counterclockwise) from the actuator.

PARTS LIST	
ITEM	DESCRIPTION
1	Tank Pad
2	Hygienic Clamp
3	Hygienic Gasket
4	Body
5	Sealing Ring
6	Diaphragm
7	Operator

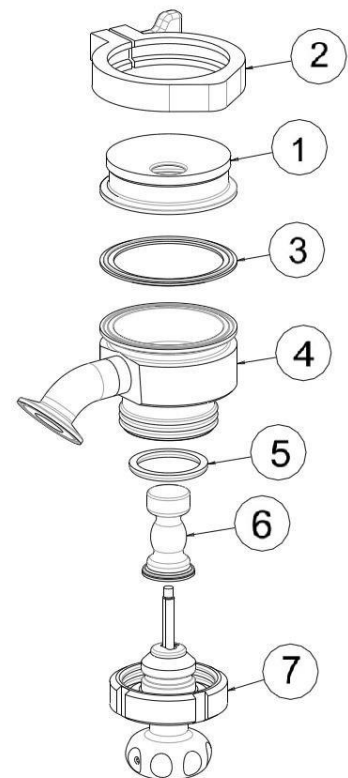

Replacing Diaphragm

Once the Diaphragm has been removed, install the new diaphragm:

1. Thread the new diaphragm (clockwise) onto the actuator.
2. **SILICONE:** Once the diaphragm is threaded on completely, ensure that the stem in the actuator is flush with the handle or actuator surface.
V-TEF™: Once the diaphragm is threaded on completely, open the operator completely, or almost completely, until the base of the diaphragm is flush with the top of the retainer before inserting into the valve body.
3. **NOTE: Inspect the diaphragm where it mates to the body and pad for debris or damage. Any debris or damage may cause the seal between the body or pad and diaphragm to become compromised.** Insert the Diaphragm into the body cavity.
4. Once the diaphragm is in the cavity, use the spanner wrench to tighten the coupling nut onto the body, to ensure that the nut is secure.
5. **Silicone:** For the silicone diaphragm, turn the handle counterclockwise, 2 full turns, to open the diaphragm up.
V-TEF™: V-TEF™ diaphragm will already be open.
6. Attach the body to the pad using the hygienic clamp. Use a new hygienic gasket for the hygienic clamp connection.

Disassembly of 1/2" Through 2" Manual Radial Diaphragm Valve:

1. Remove the Hygienic clamp that attaches the body to the pad, then remove the hygienic gasket.
2. Using the proper spanner wrench, loosen and remove the coupling nut at the base of the body.
3. Pull the operator and diaphragm out of the body cavity.
4. Unthread the diaphragm (counterclockwise) from the operator.
5. Remove the set screws from the handle, and the coupling nut can be set aside.
6. Loosen the upper retainer from the lower retainer by unthreading. Remove the O-ring from the bore of the upper retainer.
7. Remove the thrust bearings from above and below the threaded insert.
8. The stem can be unthreaded from the threaded insert in order to be cleaned.

Reassembly of 1/2" Through 2" Manual Radial Diaphragm Valve:

1. Before reassembling the radial diaphragm valve, examine the parts and repair or replace damaged or worn parts. Clean metal parts, as necessary, using a solvent compatible with the process and a non-abrasive cloth. PBM recommends using new seals at each assembly.
2. Thread the stem into the threaded insert.
3. Insert the thrust bearings above and below the threaded insert.
4. Install the O-ring into the upper retainer bore. Use a lubricant suitable for process contact on the O-ring.
5. Place the combination of the bearings, threaded insert, and stem into the lower retainer. Take the upper retainer and slide the stem through the bore. Thread the upper retainer onto the lower retainer.
6. Install the coupling nut onto the lower side of the lower retainer and then install the handle onto the exposed threaded insert. Tighten with the set screws.
7. Install and thread the diaphragm onto the stem.
8. **SILICONE:** Once the diaphragm is threaded on completely, ensure that the stem in the actuator is flush with the handle surface.
V-TEF™: Once the diaphragm is threaded on completely, open the operator completely, or almost completely, until the base of the diaphragm is flush with the top of the upper retainer on the manual operator before inserting into the valve body.
NOTE: Inspect the diaphragm where it mates to the body and pad for debris or damage. Any debris or damage may cause the seal between the body or pad and diaphragm to become compromised.
9. Insert the Diaphragm into the body cavity.

PARTS LIST	
ITEM	DESCRIPTION
1	Sealing Ring
2	Diaphragm
3	Thrust Bearing
4	Upper Retainer
5	Lower Retainer
6	Stem
7	Body
8	Coupling Nut
9	Threaded Insert
10	Handle
11	Tank Pad
12	O-ring
13	Set Screw
14	Hygienic Gasket
15	Hygienic Clamp

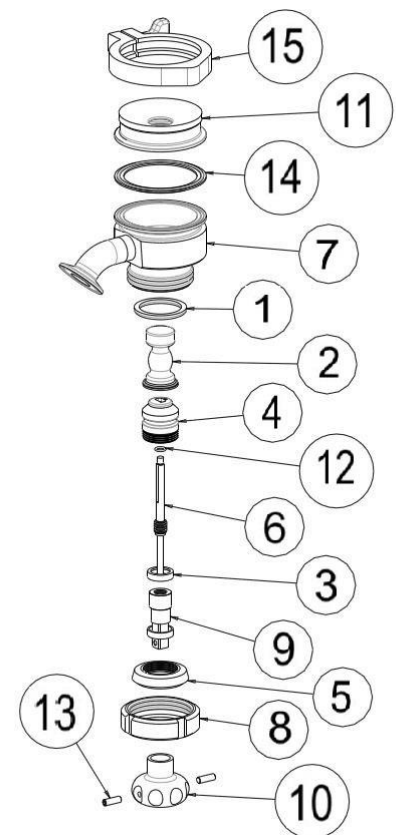

10. Once the diaphragm is in the cavity, use the spanner wrench to tighten the coupling nut onto the body, to ensure that the nut is secure.
11. **Silicone:** For silicone diaphragm, open the valve and attach the body to the pad using the hygienic clamp.
V-TEF™: V-TEF™ diaphragm will already be open. Use a new hygienic gasket for the hygienic clamp connection.

Disassembly of 1/2" Through 2" Automated Radial Diaphragm Valve:

1. Remove the Hygienic clamp that attaches the body to the pad, then remove the hygienic gasket.
2. Using the proper spanner wrench, loosen and remove the coupling nut at the base of the body.
3. Pull the actuator and diaphragm out of the body cavity.
4. Unthread the diaphragm (counterclockwise) from the actuator.
5. **WARNING! SPRING UNDER COMPRESSION:** Remove the Actuator Cap by using the appropriate spanner wrench tool.
6. Remove the springs from the actuator body.
7. Remove the piston by grabbing the lower stem. Unthread the lower stem to reveal an O-ring. Remove the O-ring
8. Remove the O-ring from the piston.
9. Remove the O-ring from the upper stem.
10. Remove the socket head cap screws from within the actuator body. This will detach the actuator body from the retainer.
11. Remove the O-ring from within the underside of the retainer.

Reassembly of 1/2" Through 2" Automated Radial Diaphragm Valve:

1. Before reassembling the radial diaphragm valve, examine the parts and repair or replace damaged or worn parts. Clean metal parts, as necessary, using a solvent compatible with the process and a non-abrasive cloth. For O-rings, use lubricant suitable for process contact. PBM recommends using new seals at each assembly.
2. Install the retainer O-ring onto the lower face of the retainer.
3. Using the socket head cap screws, assemble the actuator body onto the retainer.
4. Install the O-rings onto the upper stem, piston, and lower stem. Insert the upper stem into the bore of the piston and thread the lower stem to the upper stem. Make sure to use lubricant suitable for process contact on the piston and upper stem O-rings.
5. Lubricate the interior bore of the actuator body. Install the stem and piston assembly into the actuator body, with the upper stem fitting into the retainer bore. Push the piston in as far as possible.
6. Insert the springs into the appropriate grooves on the piston.
7. Thread the actuator cap onto the actuator body. You will need a spanner wrench to tighten the actuator cap all the way onto the actuator body.
8. Thread the diaphragm onto the stem.
9. **SILICONE:** Once the diaphragm is threaded on completely, ensure that the stem in the actuator is flush with the actuator surface.
V-TEF™: Once the diaphragm is threaded on completely, open the operator completely, or almost completely, until the base of the diaphragm is flush with the top of the retainer before inserting into the valve body.

PARTS LIST	
ITEM	DESCRIPTION
1	Sealing Ring
2	Diaphragm
3	Actuator Body
4	Retainer
5	Upper Stem
6	Piston
7	Lower Stem
8	Tank Pad
9	Body
10	Coupling Nut
11	Actuator Cap
12	Spring
13	Spring
14	Piston O-ring
15	Upper Stem O-ring
16	Retainer O-ring
17	Lower Stem O-ring
18	Socket Head Cap Screws
19	Hygienic Gasket
20	Hygienic Clamp

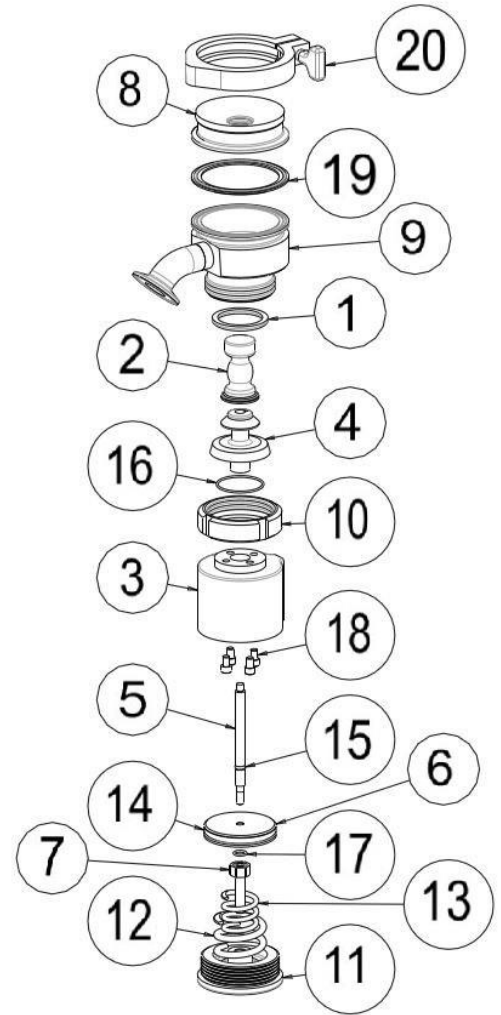

NOTE: Inspect the diaphragm where it mates to the body and pad for debris or damage. Any debris or damage may cause the seal between the body or pad and diaphragm to become compromised.

10. Insert the Diaphragm into the body cavity.
11. Once the diaphragm is in the cavity, use the spanner wrench tighten the coupling nut onto the body, to ensure that the nut is secure.
12. **Silicone:** For silicone diaphragm, open the valve and attach the body to the pad using the hygienic clamp.
V-TEF™: V-TEF™ diaphragm will already be open. Use a new hygienic gasket for the hygienic clamp connection.

Disassembly of 3” and 4” Manual Radial Diaphragm Valve:

1. Remove the Hygienic clamp that attaches the body to the pad, then remove the hygienic gasket.
2. Using the proper spanner wrench, loosen and remove the coupling nut at the base of the body.
3. Pull the operator and diaphragm out of the body cavity.
4. Unthread the diaphragm (counterclockwise) from the operator.
5. Remove the set screws from the handle, and the coupling nut can be set aside.
6. Loosen the upper retainer from the lower retainer by unthreading. Remove the O-ring from the bore of the upper retainer.
7. Remove the thrust ball bearings and washers from above and below the threaded insert.
8. The stem can be unthreaded from the threaded insert in order to be cleaned.

Reassembly of 3” and 4” Manual Radial Diaphragm Valve:

1. Before reassembling the radial diaphragm valve, examine the parts and repair or replace damaged or worn parts. Clean metal parts, as necessary, using a solvent compatible with the process and a non-abrasive cloth. PBM recommends using new seals at each assembly.
2. Thread the stem into the threaded insert.
3. Install the O-ring into the upper retainer bore. Use a lubricant suitable for process contact on the O-ring.
4. Thread the stem into the brass threaded insert.
5. Insert the thrust ball bearings into the cavity of the upper retainer. The bearings should be installed with washer first, followed by the ball bearing, and then the washer. The threaded insert, with a stem, goes next, followed by washer, ball bearing, and washer.
6. Take the combination of the bearings, threaded insert, stem, and upper retainer and thread the upper retainer into the lower retainer.
7. Install the coupling nut onto the lower side of the lower retainer and then install the handle onto the exposed threaded insert. Tighten with the set screws.
8. Install and thread the diaphragm onto the stem.
9. **SILICONE:** Once the diaphragm is threaded on completely, ensure that the stem in the actuator is flush with the handle surface.
V-TEF™: Once the diaphragm is threaded on completely, open the operator completely, or almost completely, until the base of the diaphragm is flush with the top of the upper retainer on the manual operator before inserting into the valve body.
NOTE: Inspect the diaphragm where it mates to the body and pad for debris or damage. Any debris or damage may cause the seal between the body or pad and diaphragm to become compromised.
10. Insert the Diaphragm into the body cavity.
11. Once the diaphragm is in the cavity, use the spanner wrench tighten the coupling nut onto the body, to ensure that the nut is secure.
12. **Silicone:** For silicone diaphragm, open the valve and attach the body to the pad using the hygienic clamp.
V-TEF™: V-TEF™ diaphragm will already be open. Use a new hygienic gasket for the hygienic clamp connection.

PARTS LIST	
ITEM	DESCRIPTION
1	Pad
2	Hygienic Clamp
3	Body
4	Diaphragm
5	Upper Retainer
6	Stem O-Ring
7	Ball Bearing Set
8	Stem
9	Peek Sleeve
10	Threaded Insert
11	Lower Retainer
12	Coupling Nut
13	Handle
14	Set Screw
15	Sealing Ring

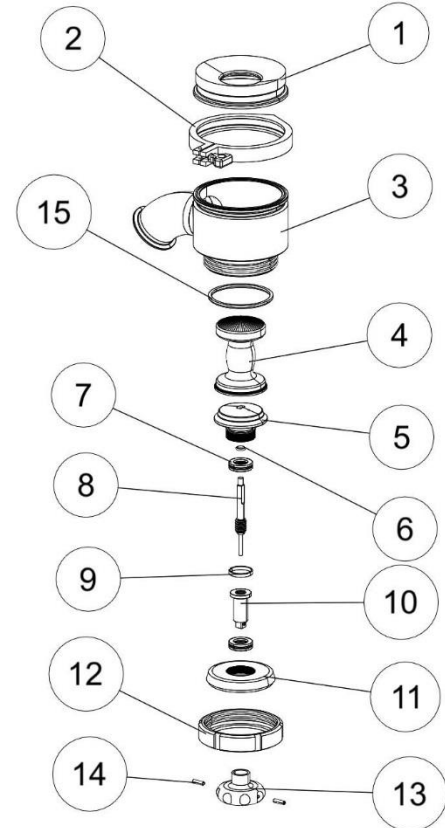

Disassembly of 3" and 4" Automated Radial Diaphragm Valve:

1. Remove the Hygienic clamp that attaches the body to the pad, and remove the hygienic gasket.
2. Using the proper spanner wrench, loosen and remove the coupling nut at the base of the body.
3. Pull the actuator and diaphragm out of the body cavity.
4. Unthread the diaphragm (counterclockwise) from the actuator.
5. **WARNING! SPRING UNDER COMPRESSION:** Remove the Actuator Cap by loosening and removing the bolts.
6. Remove the spring assembly from the actuator body.
7. Remove the piston by grabbing the lower stem. Unthread the lower stem to reveal an O-ring. Remove the O-ring.
8. Remove the O-ring from the piston.
9. Remove the O-ring from the upper stem.
10. Remove the socket head cap screws from within the actuator body. This will detach the actuator body from the retainer.
11. Remove the O-ring from within the underside of the retainer.

PARTS LIST	
ITEM	DESCRIPTION
1	Pad
2	Hygienic Clamp
3	Hygienic Gasket
4	Body
5	Diaphragm
6	Upper Retainer
7	Retainer O-Ring
8	Coupling Nut
9	Actuator Body
10	Socket Head Cap Screws
11	Upper Stem
12	Upper Stem O-Ring
13	Piston O-Ring
14	Piston
15	Lower Stem O-ring
16	Lower Stem
17	Spring Assembly
18	Actuator Cap O-Ring
19	Actuator Cap
20	Hex Head Cap Screws
21	Sealing Ring

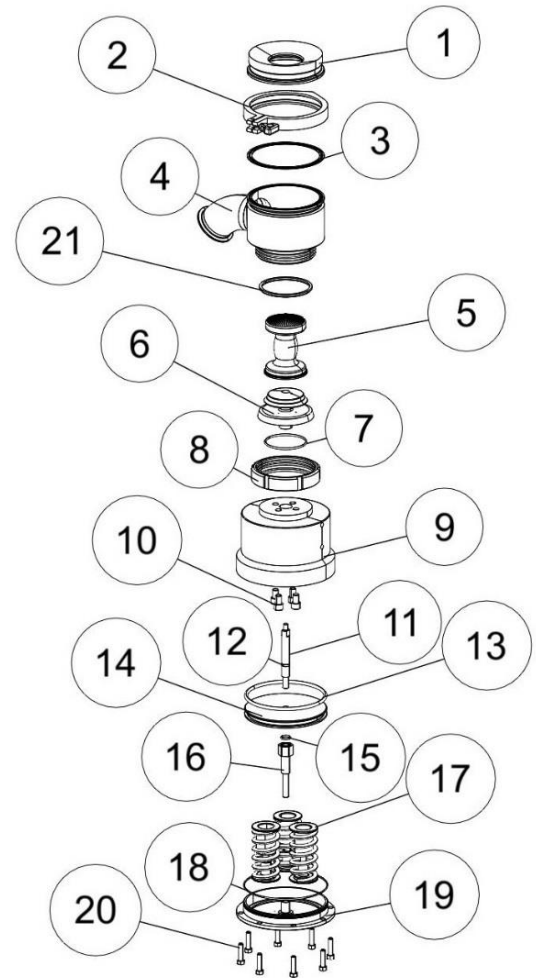

Reassembly of 3" and 4" Automated Radial Diaphragm Valve:

1. Before reassembling the radial diaphragm valve, examine the parts and repair or replace damaged or worn parts. Clean metal parts, as necessary, using a solvent compatible with the process and a non-abrasive cloth. For O-rings, use lubricant suitable for process contact. PBM recommends using new seals at each assembly.
2. Install the retainer O-ring onto the lower face of the retainer.
3. Using the socket head cap screws, assemble the actuator body onto the retainer.
4. Install the O-rings onto the upper stem, piston, and lower stem. Insert the upper stem into the bore of the piston and thread the lower stem to the upper stem. Make sure to use lubricant suitable for process contact on the piston and upper stem O-rings.
5. Lubricate the interior bore of the actuator body. Install the stem and piston assembly into the actuator body, with the upper stem fitting into the retainer bore. Push the piston in as far as possible.
6. Insert the spring assembly into the appropriate grooves on the piston.
7. Place the actuator cap onto the actuator body. Bolt down using a star pattern, so the end cap goes on evenly.
8. Thread the diaphragm onto the stem.
9. **SILICONE:** Once the diaphragm is threaded on completely, ensure that the stem in the actuator is flush with the actuator surface.
V-TEF™: Once the diaphragm is threaded on completely, open the operator completely, or almost completely, until the base of the diaphragm is flush with the top of the retainer before inserting into the valve body.
NOTE: Inspect the diaphragm where it mates to the body and pad for debris or damage. Any debris or damage may cause the seal between the body or pad and diaphragm to become compromised.
10. Insert the Diaphragm into the body cavity.
11. Once the diaphragm is in the cavity, use the spanner wrench tighten the coupling nut onto the body, to ensure that the nut is secure.
12. **Silicone:** For silicone diaphragm, open the valve and attach the body to the pad using the hygienic clamp.
V-TEF™: V-TEF™ diaphragm will already be open. Use a new hygienic gasket for the hygienic clamp connection.

Radial Diaphragm Valve and Coupling Size Information:

VALVE SIZE	COUPLING NUT NOMINAL DIAMETER	COUPLING NUT THREAD PER DIN 405-1
1/2", 3/4"	DN 32	RD 58 x 1/6
1"	DN 40	RD 65 x 1/6
1-1/2"	DN 50	RD 78 x 1/6
2"	DN 65	RD 95 x 1/6
3"	DN 100	RD 130 x 1/4
4"	DN 125	RD 160 x 1/4

Note: Spanner wrench size can be obtained by using nominal diameter.

Coupling/Spanner Size Information:

Note: PBM recommends obtaining an adjustable hook spanner wrench.

VALVE SIZE	A	B	C	SPANNER SIZE
1/2", 3/4"	2.756	2.441	.32	1-1/4" to 3"
1"	3.071	2.744	.39	2" to 4-3/4"
1-1/2"	3.622	3.307	.39	2" to 4-3/4"
2"	4.409	4.016	.39	2" to 4-3/4"
3"	5.827	5.433	.47	4-1/2" to 6-1/4"
4"	7.008	6.614	.47	6-1/8" to 8-3/4"

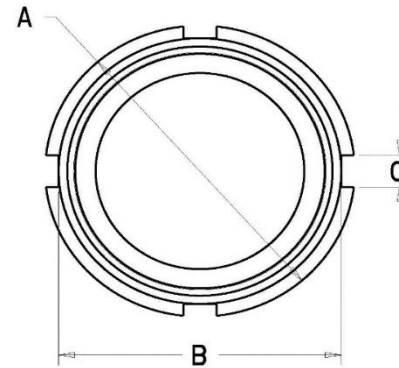

Radial Diaphragm Replacement Parts Information:

Valve Size	RD Silicone Diaphragm	RD V-TEF™ Diaphragm	Silicone Body Clamp Gasket	PTFE Body Clamp Gasket	EPDM Body Clamp Gasket
1/2", 3/4"	RDSID102	RDTFD102	RDSID113A-	RDTFD113A-	RDEPD113A-
1"	RDSIE102	RDTFE102	RDSIG113A-	RDTFG113A-	RDEPG113A-
1-1/2"	RDSIG102	RDTFG102	RDSIG113A-	RDTFG113A-	RDEPG113A-
2"	RDSIH102	RDTFH102	RDSIH113A-	RDTFH113A-	RDEPH113A-
3"	RDSIK102	RDTFK102	RDSIK113A-	RDTFK113A-	RDEPK113A-
4"	N/A	RDTFL102	N/A	RDTFK113A-	RDEPK113A-



1070 Sandy Hill Road, Irwin, PA 15642

Phone: (724) 863-0550 or (800) 967-4PBM Fax: (724) 864-9255

E-mail: info.pbmvalve@imi-critical.com Web: www.pbmvalve.com

© Copyright 2021 PBM, Inc. IOM-RD1 R2 10/21 Printed in USA

