

IMI PBM

INDUSTRIAL VALVES



IMI Critical
Engineering

Adjust-O-Seal® Feature

- IMI PBM valves with adjustable sealing provide bidirectional upstream sealing.
- Valve body bolts can be tightened to compensate for normal seat wear without having to remove the valve from service.

Competitor's Design

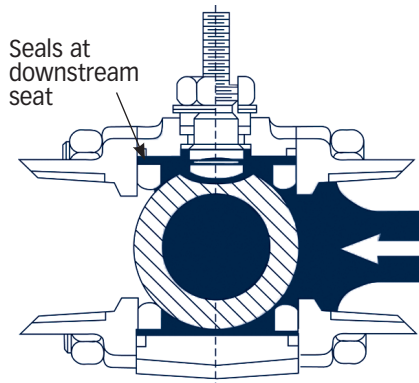

Line pressure pushes ball downstream in the ball-closed position, providing sealing at the downstream seat. There is no adjustment to compensate for seat wear.

IMI PBM's Design

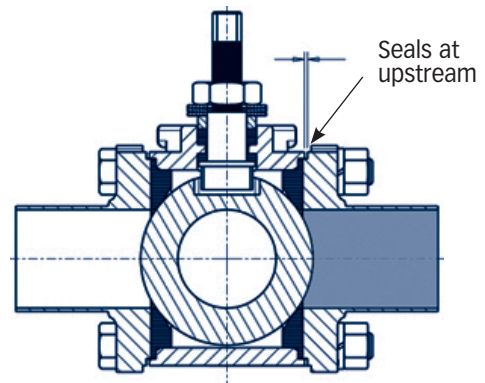

Valve body bolts compress valve seats against the ball, providing bidirectional sealing at the upstream seat. To compensate for seat wear, body bolts can be slightly tightened to recompress seats against ball.

IMI PBM valves offer value over the life of the product with:

- Fewer process interruptions
- Longer life
- Clean/drain without process interruption
- Improved product yields





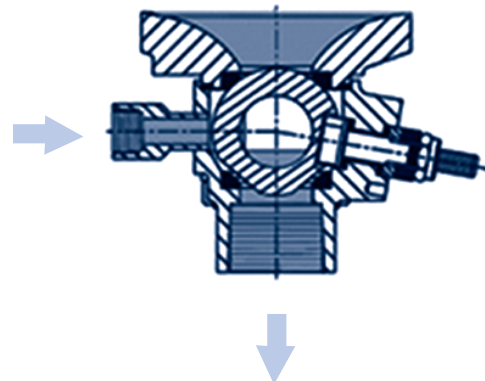

IMI PBM also offers:

- On-time delivery
- Documentation
- Solutions to tough applications

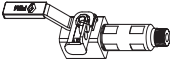

This means on valves mounted vertically like IMI PBM's angle stem flush tank valve, the valve seats on the upstream seat, thus allowing the body to be purged and drained without process interruption.

Table of Contents

ITEM	PAGE
Features	2
Ordering information	4-5
Materials of Construction	6
Seat & Seal materials	6
Allowable working pressures and temperature	7
Pressure and temperature charts; Cv factors	8
Torque values	9
Testing	10
Available options	10-11
Flow patterns	12
Metal Seats	13
Specifications	14-15
Instrument Valves 	16-17
Bolted Instrument Valves 	18-19
Transmitter Isolation Valves 	20
Manifold Assemblies 	21
Flush/Bleed Rings 	22
Cryogenic Valves 	23
Automation and Controls 	24-25

VALVE CONFIGURATION ORDERING INFORMATION

Number(s) in parentheses indicate valve configuration part number position

Part Number Position	1	2	3	4	5	6	7	8	9	10	11	12	13	14	15	16	17	18	19	20
Part Number Code Example	S	P	H	L	E	5	Q	-	G	-	-	-	3	4	A	-	V	X	X	X

PRODUCT (1-2)		MATERIAL(2) (3-4)	SIZE (5)	SERIES (6)	END CONNECTION(3) (7-8)	SEAT & SEAL/FILLERS/O-RINGS (IF USED) (9)
AN ANSI	A- Aluminum	A 1/4	4 Series 4	B- Ext. Sch 40 buttweld	F(9) Metal	O-RING None
CN Cryogenic (ANSI)	C- Hastelloy® C-276	B 3/8	5 Series 5	D- Ext. Sch 10 buttweld	G TF	VI
CD Cryogenic 3-way	C1 Hastelloy® B2	C 1/2	6 Series 6	J- Ext. socket weld	H HT	VI
CP Cryogenic	D- Iron(6)	D 3/4		L- 150# Flange	I HT	VI
DD Diverter (Steam)	E- Carbon Steel(6)	E 1		M- 300# Flange	J TF	VI
DP Diverter Port	G- Lead Free Bronze	F 1-1/4		P- Male NPT	K UT	VI
FD Flush Tank (Steam)	H- 316/316L Stainless	G 1-1/2		Q- Female NPT	L UT	VI
FT Flush Tank	HC Alloy 20	H 2		Q1 BSPT	M UT	VI
MP Multi-Port	HL 316L Stainless	J 2-1/2		S- Sil-braze1 groove (pipe)	Q(9) CG	None
SP Industrial 2-way	HF F316L Forged	K 3		T- Solder joint (tube)	Y CT	None
SD SP (Steam)	H2 317L Stainless	L 4		U- Socket weld (pipe)	Z TF	EP
	I- Inconel® 600	M 6		-Z No end fittings	0 HT	EP
	M- Monel 400				1 HT	VT
	N- 922 Bronze				2 TF	VT
	P- AL6XN			For other end fittings, Consult Factory	3 UT	EP
	R- 955 NiAl-Bronze				4 UT	EP
	S- 953 Al-Bronze				5 UT	EP
	T- Gr. 5 Titanium				9 TF	VV
	T2 Gr. 2 Titanium					
	T7 Gr. 7 Titanium					
	W- Nickel 200					
	X- 958 NiAl-Bronze					
	Z- 70/30 CuNi					
	1- 90/10 CuNi					
	5- Inconel® 625					
	9- 954 Al-Bronze					
	25 254SMO®6Mo					
	22 Duplex 2205					
	76 Super Duplex 32760					
	For other materials, Consult Factory					

SEAT/SEAL/MATERIAL CODES	
CG	Carbon-Graphite
HT	S-TEF®
CT	C-TEF™
TF	V-TEF™
VT	VTFE (Cavity Fillers Only)
UT	UHMWPE
F	Metal Seats

O-RING MATERIAL CODES	
EP	EPR
VI	FKM
VV	FEP Encapsulated FKM

Column 8 options	
3	Non Adjust-O-Seal®
4	Reduced port
5	Non Adjust-O-Seal® & Reduced port
7	Flat-faced flanges
9	Bar-stock

O-RINGS ARE NOT USED IN ALL VALVE PRODUCTS - SEE EACH RESPECTIVE PAGE	
---	--

View our Industrial Product Bulletins online

www.pbmvalve.com/product-bulletins/

ANGLE STEM VALVES

- PB-AF1
- PB-AF3

ANSI BALL VALVES

- PB-AN5
- PB-AN5-DBB
- PB-AN6
- PB-AN6-DBB

CYROGENIC VALVES

- PB-C6
- PB-CD6
- PB-CN6
- PB-CN600#
- PB-CP6

DIVERTER PORT VALVES

- PB-DD5
- PB-DP5

FLUSH TANK VALVES

- PB-FD5
- PB-FT5
- PB-FT6

INSTRUMENT VALVES

- PB-IB
- PB-IB-DBB
- PB-IM

MULTI-PORT VALVES

- PB-MP5

2-WAY VALVES

- PB-SD5
- PB-SP5
- PB-SP6

TRANSMITTER ISOLATION VALVES

- PB-TIV

OTHER

- PB-LFB

VALVE CONFIGURATION ORDERING INFORMATION

Number(s) in parentheses indicate valve configuration part number position
PBM part numbers can have up to 20 alpha-numeric characters

Part Number Position	1	2	3	4	5	6	7	8	9	10	11	12	13	14	15	16	17	18	19	20
Part Number Code Example	S	P	H	L	E	5	Q	-	G	-	-	-	3	4	A	-	V	X	X	X

INDUSTRIAL VALVES			
FLOW PATTERN/TANK PAD/PURGE OPTIONS (10 & 11)	BALL / STEM OPTIONS (12)	OPERATOR OPTIONS (13 & 14)	POLISH OPTIONS (15)

DIVERTER PORT AND MULTI-PORT VALVES
FOR DIVERTER AND MULTI-PORT VALVES, USE POSITION 10 & 11 TO INDICATE THE FLOW PATTERN - SEE PAGE 8 FOR COMMON FLOW PATTERNS

FLUSH TANK OPTIONS (●●POSITION 10 & 11●●)
-- Standard flush tank weld pad
02 Less tank weld pad but with plastic or wood shipping pad

- 5 w/1" bolt-on tank pad
- 6 w/1.5" bolt-on tank pad
- 7 w/2" bolt-on tank pad
- 8 w/3" bolt-on tank pad
- 9 w/4" bolt-on tank pad
- 10 w/6" bolt-on tank pad
- 11 w/8" bolt-on tank pad

PURGE PORT OPTIONS (●●POSITION 1 ONLY●●)

- No purge option(s) selected¹
- A (1) 1/2" clamp on center 90° from stem
- B (1) 1/2" clamp on center opposite stem
- C (1) 1/2" clamp upstream 90° from stem
- D (1) 1/2" clamp downstream opposite stem
- E (2) 1/2" clamp (1) on center 90° from stem & (1) opposite stem
- F (2) 1/2" clamp (1) upstream 90° from stem & (1) downstream opposite stem
- G (1) 1/2" BWTE on center 90° from stem
- H (1) 1/2" BWTE on center opposite stem
- I (1) 1/2" BWTE upstream 90° from stem
- J (1) 1/2" BWTE downstream opposite stem
- K (2) 1/2" BWTE on center (1) 90° from stem & (1) opposite stem
- L (2) 1/2" BWTE upstream 90° from stem & (1) downstream opposite stem
- M (1) 1/4" FNPT on center 90° from stem
- N (1) 1/4" FNPT on center opposite stem
- O (1) 1/4" FNPT upstream 90° from stem
- P (1) 1/4" FNPT downstream opposite stem
- Q (2) 1/4" FNPT on center 90° from stem & (1) opposite stem
- R (2) 1/4" FNPT (1) upstream 90° from stem & (1) downstream opposite stem

BALL HOLE & FLAT OPTIONS (●●POSITION 11 ONLY●●)

- No ball options selected position
- A Flats in closed downstream position
- B Flats in closed upstream position
- C Flats in open upstream position
- D Flats in open downstream position
- E Flats in open upstream & downstream position
- F Holes in closed downstream position
- G Holes in closed upstream position
- H Ball with vent hole (downstream)
- I Ball with (2) crown flats
- J Standard width slotted ball
- K 30° V-ball
- L 45° V-ball
- M 60° V-ball
- N Self-flush ball with flats closed downstream
- O Self-flushing ball
- P Ball with vent hole (upstream)

Polish Notes

- On ID polished valves, the body, ball, seat retainer (if applicable) and end fittings are polished
- On ID/OD polished valves, the body, ball, seat retainer (if applicable) and end fittings are polished
- On ID+EP polished valves, the body, ball, seat retainer (if applicable) and end fittings are polished (Stem is EP'd)

- Standard (316/316L ball & stem)
- F Internal / external grounding
- G 17-4PH stem
- I Monel ball
- J 932 Bronze ball
- K Monel stem & followers
- L Monel ball, stem & followers
- M Aluminum ball
- N 922 Bronze ball
- O Hastelloy C-276 ball
- P C-276 ball, stem & followers
- Q 922 Bronze ball w/Monel stem
- R Monel stem, followers & bolting
- S Monel ball, stem, followers & bolting
- T 922 Bronze ball, Monel stem & followers, Silicon Bronze bolting & CuSi fasteners
- U 922 Bronze ball w/Monel stem & followers
- V 12" extended stem/body bonnet (cryo only)
- 1 Chrome carbide (ball & seat coating)
- 2 Tungsten carbide (ball & seat coating)

24vac 24vac 24vac 24vac 24vac
PBM, Asco & Westlock combo

- 55 DA80 psig actr & GP Sol ↔
- 56 DA80 psig actr & GP LS & Sol ↔
- 57 DA80 psig actr & XP Sol ↔
- 58 DA80 psig actr & XP LS & Sol ↔
- 59 DA60 psig actr & GP Sol ↔
- 60 DA60 psig actr & GP LS & Sol ↔
- 61 DA60 psig actr & XP Sol ↔
- 62 DA60 psig actr & XP LS & Sol ↔
- 63 SR80 psig actr & GP Sol ↔
- 64 SR80 psig actr & GP LS & Sol ↔
- 65 SR80 psig actr & XP Sol ↔
- 66 SR80 psig actr & XP LS & Sol ↔
- 67 SR60 psig actr & GP Sol ↔
- 68 SR60 psig actr & GP LS & Sol ↔
- 69 SR60 psig actr & XP Sol ↔
- 70 SR60 psig actr & XP LS & Sol ↔

Standard Asco solenoids (12vac & 24vac)

- GP - WT8551A001MS
- XP - EF8551A001MS
- solenoids are not wired to position monitors

Standard Westlock position monitors

- GP - 2004NBY2A2M0200
- XP - 2007NBY2B2M0200

Standard TopWorx position monitors

- GP/XP - TXP-M21GNEM

Standard TopWorx proximity position monitor

- GP/XP - TXP-P21GNEM

- w/handle
- 00 Stainless locking oval hand wheel(a)
- 02 w/o handles, w/stem actr prep
- 03 w/handle, w/stem actr prep
- 04 Locking lever handle
- 05 w/stainless oval hand wheel(a)
- 07 w/45° handle
- 08 w/gear operator
- 09 w/T-handle
- 10 w/manual spring return handle(b)
- 11 w/fusible link SR handle (165°F)Ⓢ
- 12 w/vane actr for 80psig
- 13 w/GP electric actuator
- 14 w/XP electric actuator
- 17 w/ext lockable oval hand wheel (a)
- 18 w/ext lockable lever handle
- 71 w/ext lockable lever handle - Sanitary(a)
- 72 w/ext lockable oval hand wheel - Sanitary (a)

120vac 120vac 120vac
PBM, Asco & Westlock combo

- 20 DA80 psig actr
- 21 DA80 psig actr & GP LS
- 22 DA80 psig actr & GP Sol
- 23 DA80 psig actr & GP LS & Sol
- 24 DA80 psig actr & XP LS
- 25 DA80 psig actr & XP Sol
- 26 DA80 psig actr & XP LS & Sol
- 27 DA60 psig actr
- 28 DA60 psig actr & GP LS
- 29 DA60 psig actr & GP Sol
- 30 DA60 psig actr & GP LS & Sol
- 31 DA60 psig actr & XP LS
- 32 DA60 psig actr & XP Sol
- 33 DA60 psig actr & XP LS & Sol
- 34 SR80 psig actr
- 35 SR80 psig actr & GP LS
- 36 SR80 psig actr & GP Sol
- 37 SR80 psig actr & GP LS & Sol
- 38 SR80 psig actr & XP LS
- 39 SR80 psig actr & XP Sol
- 40 SR80 psig actr & XP LS & Sol
- 41 SR60 psig actr
- 42 SR60 psig actr & GP LS
- 43 SR60 psig actr & GP Sol
- 44 SR60 psig actr & GP LS & Sol
- 45 SR60 psig actr & XP LS
- 46 SR60 psig actr & XP Sol
- 47 SR60 psig actr & XP LS & Sol
- 51(d) DA80 psig actr & position indicator
- 52(d) DA60 psig actr & position indicator
- 53(d) SR80 psig actr & position indicator
- 54(d) SR60 psig actr & position indicator

PBM, Asco & Topworx combo - 120vac

- 73 DA80 psig actr & XP LS
- 74 DA80 psig actr, XP LS+GP Sol
- 75 DA80 psig actr, XP LS+XP Sol
- 76 DA60 psig actr & XP LS
- 77 DA60 psig actr & XP LS+GP Sol
- 78 DA60 psig actr & XP LS+XP Sol
- 79 SR80 psig actr & XP LS
- 80 SR80 psig actr, XP LS+GP Sol
- 81 SR80 psig actr, XP LS+XP Sol
- 82 SR60 psig actr & XP LS
- 83 SR60 psig actr & XP LS+GP Sol
- 84 SR60 psig actr & XP LS+XP Sol
- 85 DA80 psig actr & XP Prox
- 86 DA80 actr, XP Prox+XP Sol
- 87 DA60 psig actr & XP Prox
- 88 DA60 actr, XP Prox+XP Sol
- 89 SR80 psig actr & XP Prox
- 90 SR80 actr, XP Prox+XP Sol
- 91 SR60 psig actr & XP Prox
- 92 SR60 actr, XP Prox+XP Sol

- Standard polish
- A 20Ra ID
- B 32Ra OD
- C 20Ra ID / 32Ra OD
- D 15Ra ID
- E 10Ra ID
- F 20Ra ID after EP
- G 15Ra ID after EP
- H 10Ra ID after EP
- I 5Ra ID
- K 5Ra ID / 32Ra OD
- L 20Ra ID / 32Ra OD / EP
- M EP ID
- N 10 Ra ID / 32Ra OD
- O 15Ra ID / 32Ra OD / EP
- Q 15Ra ID / 32Ra OD
- S 10Ra ID / 32Ra OD / EP

LOX & BOLTING OPTIONS (16)

- No option(s) required
- L LOX cleaning per PBM procedure
- M LOX & CRN bolting
- Z CRN bolting

SPECIAL ENGINEERING# (17 - 20)

Special engineering number columns - consult PBM
Example: VXXX suffix at end of standard PBM part number

AUTOMATION NOTES

- (a) for 2" and smaller valves
- (b) for 1-1/2" and smaller valves
- (c) for 3" and smaller valves
- (d) consult PBM for beacon indicators

ABBREVIATION INDEX

- GP = General Purpose
- XP = Explosion Proof
- LS = Limit Switch
- Sol = Solenoid - N/C
- DA = Double Acting
- SR = Spring Return - FCW

Materials

Stainless Steel

316 S/S complies with ASTM A 351-CF8M or A479, S31600

316L S/S complies with ASTM A 351-CF3M or A479, S31603

- Is exceptionally corrosion-resistant to acidic and basic environments and does not pit easily.
- Can be polished to a near-mirror finish for easy cleanability.
- Weld fittings have a carbon content of < 0.3% to facilitate welding.

Carbon Steel, A216-WCB

- This versatile material handles mildly corrosive media.

Bronze, Alloy 922

- Excellent resistance to sea water environments and good steam resistance. Also suitable for sub-zero temperature applications.

Hastelloy® C-276

- Very good in corrosion reducing and mildly oxidizing environments. Very good resistance to localized attack and stress corrosion cracking. Alloy CW-12MW in cast form.

Others

- Additional materials are available, including Alloy 20, Bronze, Duplex Stainless Steels, Hastelloys, Titanium, and Inconel®.

Seat and Seal Materials

Designation	Description	Color	Purpose
V-TEF™	Chemically Modified PTFE IMI PBM Standard for Series 4, 5 6, & 7	White	Suitable for applications under 400°F. This chemically modified PTFE material is IMI PBM's standard seat and seal material. It combines the ruggedness of a filled PTFE with the low coefficient of friction of virgin PTFE. V-TEF™ also has much improved porosity control and deformation under load when compared to PTFE grades. FDA and USP Class VI compliant. Meets bubbletight seat leakage.
RTFE	Glass Reinforced PTFE	Slightly Off White	Suitable for applications under 400°F. Used in a variety of applications. Bubbletight leakage.
VTFE	Virgin PTFE	White	Suitable for applications under 350°F. A low stem torque material ideal for sanitary use. FDA and USP Class VI compliant. Meets bubbletight seat leakage.
S-TEF®	Stainless Steel Reinforced PTFE	Charcoal Gray	Suitable for applications under 450°F. A suitable material for higher pressure/temperature applications. Higher stem torque than virgin grades and V-TEF™. USP Class VI compliant. Meets bubbletight seat leakage.
CARBON	Carbon/Graphite	Black	Suitable for applications under 750°F (400°C). A hard material impervious to high temperatures. It is used for heat transfer fluid applications and other high temperature applications. Meets Class V seat leakage.
UHMWPE	Ultra High Molecular Weight Polyethylene	Off White	Suitable for applications under 200°F. An extremely wear resistant material having a wear rate about 1/10th that of PTFE. FDA compliant and is used in high cycle applications where possible. Meets bubbletight seat leakage.
PEEK®	Poly ether ether ketone	Putty	Suitable for applications under 500°F. PEEK® is a rugged, high strength material having fairly high stem torque. IMI PBM's PEEK® is 10 weight percent PTFE to reduce the hardness of virgin PEEK®. FDA compliant and meets Class V seat leakage.
KYNAR®	Polyvinylidene Fluoride	Slightly Transparent White	Suitable for applications under 250°F. Kynar® has been used successfully in abrasive service and is suitable for radiation environments where gamma levels accumulate to 1,000 megarads. FDA and USP Class VI compliant. Meets bubbletight seat leakage.

NOTES:

1. PTFE is Polytetrafluorethylene.
2. Seat and seal materials may be mixed in a valve in order to provide media-compatibility and the appropriate torque, temperature and pressure ratings.
3. Temperature ratings above based on 0 psi. See Pressure & Temperature charts on page 8.

Allowable Working Pressures and Temperatures

Valve Style/ Series	Material	Size (inches)	Non-Flanged					
			-20 to 100°F	-28.9 to 37.8°C	300°F	148.9°C	450°F	232.2°C
			psig	barg	psig	barg	psig	barg
SP, SD, DP, DD FT, FD Series 5	316 SS/316L	1-1/2" (DN40) and smaller	900	62.1	770	53.1	680	46.9
	316 SS/316L	2" and larger	720	49.6	620	42.7	540	37.2
	C-276	All	600	41.4	520	35.9	450	31.0
	Carbon Stl.	1-1/2" (DN40) and smaller	900	62.1	770	53.1	680	46.9
	Carbon Stl.	2" (DN50) and larger	740	51.0	655	45.2	620	42.7
SP, SD Series 5	922 Bronze	All	600	41.4	600	41.4	580	40.0
SP, FT, Series 6	316 SS/316L	3" (DN80) and smaller	720	49.6	620	42.7	540	37.2
	Carbon Stl.	3" (DN80) and smaller	740	51.0	655	45.2	620	42.7
CN	316 SS/316L	All	See Flanged Table at Right.					
AN, All Series	C-276	All						
	Carbon Steel	All						
	Bronze	All						
CP, CD Series 6	316 SS/316L	All	720	49.6	620	42.7	540	37.2
MP Series 1	836/922 Bronze	1-1/2" (DN40) and smaller	400	27.6	385	26.5	360	24.8
	836/922 Bronze	2" (DN50)	350	24.1	340	23.4	315	21.7
	836/922 Bronze	3" (DN80)	300	20.7	290	20.0	270	18.6
	836/922 Bronze	4" (DN100)	See Flanged Table at Right					
	Ductile Iron	1-1/2" (DN40)	550	37.9	440	30.3	340	23.4
	Ductile Iron	2" (DN50)	500	34.5	400	27.6	310	21.4
	Ductile Iron	3" (DN80)	450	31.0	360	24.8	280	19.3
	Ductile Iron	4" (DN100)	See Flanged Table at Right					
MP, Series 4	316 SS/316L	3/4" (DN20) and smaller	900	62.1	770	53.1	680	46.9
	316 SS/316L	1" (DN 25) thru 4" (DN100)	720	49.6	620	42.7	540	37.2
	316 SS/316L	6" (DN150)	275	19.0	205	14.1	195	13.4
	C-276	3/4" (DN20) and smaller	900	62.1	770	53.1	680	46.9
	C-276	1" (DN25) thru 4" (DN100)	720	49.6	620	42.7	540	37.2
	C-276.	6" (DN150)	275	19.0	205	14.1	195	13.4
	Carbon Stl.	3/4" (DN20) and smaller	900	62.1	770	53.1	680	46.9
	Carbon Stl.	1" (DN25) thru 4" (DN100)	740	51.0	655	45.2	620	42.7
MP, Series 5	316 SS/316L	All	275	19.0	205	14.1	195	13.4
	C-276	All	230	15.9	200	13.8	180	12.4
	Carbon Stl.	All	285	19.7	230	15.9	185	12.8
AF Series 1	316 SS/316L	1-1/2" (DN40) and smaller	900	62.1	770	53.1	680	46.9
	316 SS/316L	2" (DN50)	550	37.9	540	37.2	525	36.2
	316 SS/316L	3" (DN80)	625	43.1	610	42.1	600	41.4
	316 SS/316L	4" (DN100)	550	37.9	540	37.2	525	36.2
	316 SS/316L	6" (DN150)	375	25.9	365	25.2	360	24.8
	C-276	1-1/2" (DN40) and smaller	600	41.4	520	35.9	475	32.8
	C-276	2" (DN50), 4" (DN100)	550	37.9	540	37.2	525	36.2
	C-276	3" (DN80)	600	41.4	520	35.9	475	32.8
	C-276	4" (DN100)	550	37.9	540	37.2	525	36.2
	C-276	6" (DN150)	375	25.9	320	22.1	280	19.3
AF Series 3	316 SS/316L	1-1/2" (DN40) and smaller	720	49.6	620	42.7	540	37.2
	316 SS/316L	2" (DN50), 4" (DN100)	550	37.9	540	37.2	525	36.2
	316 SS/316L	3" (DN80)	625	43.1	610	42.1	600	41.4
	316 SS/316L	4" (DN100)	550	37.9	540	37.2	525	36.2
	316 SS/316L	6" (DN150)	375	25.9	365	25.2	360	24.8
TIV Series 5, 6	316 SS/316L	All	See Flanged Table at Right					
	C-276	All						
	Carbon Stl.	All						

Valid for all flanged valves:

ANSI 150# FLANGE						
Valve Material	-20° to 100° F psig	- 2 8 ° to 38° C barg	300° F psig	150° C barg	450° F psig	232° C barg
836 Bronze	225	15.5	180	12.4	135	9.3
922 Bronze	225	15.5	195	13.4	160	11.0
955 Bronze	225	15.5	195	13.4	160	11.0
C-276	230	15.9	200	13.8	180	12.4
316/316L S/S	275	19.0	215	14.8	180	12.4
Carbon Steel.	285	19.7	230	15.9	185	12.8
ANSI 300# FLANGE						
Valve Material	-20° to 100° F. psig	- 2 8 ° to 38° C. barg	300° F. psig	150° C. barg	450° F. psig	232° C. barg
C-276	600	41.4	520	35.9	475	32.8
316/316L S/S	720	49.6	560	38.6	495	34.1
Carbon Steel	740	51.0	655	45.2	620	42.7

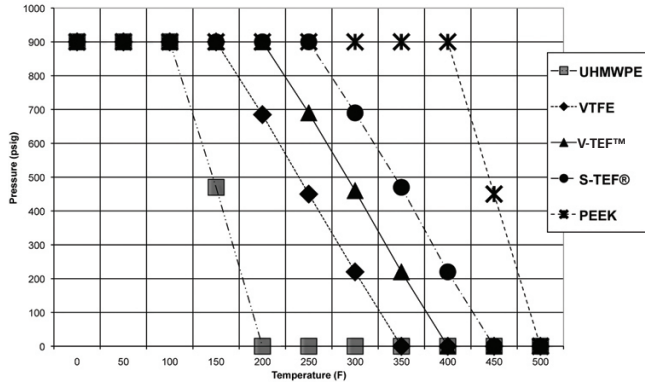
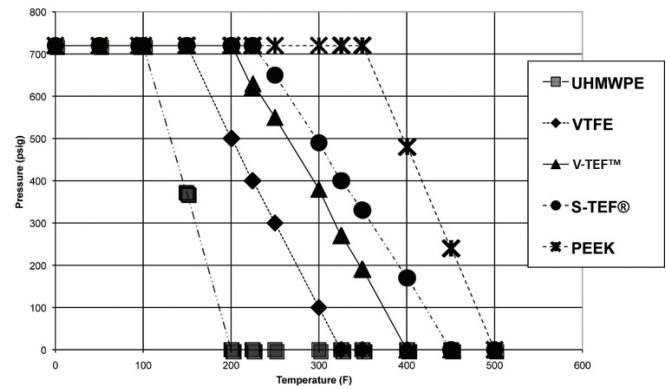
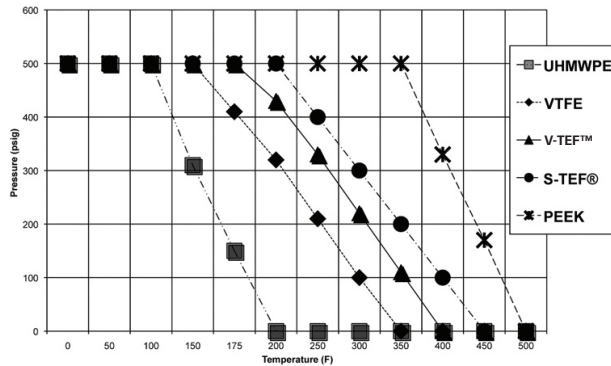
Valves 1-1/2-Inch and Smaller

2-Inch to 3-Inch

4 and 6-Inch

Seat & Seal Temperature and Pressure Charts

Cv Values (gpm)

VALVE SIZE	2-WAY			FLUSH TANK		DIVERTER PORT						
	SP	CP	AN, CN	AF	FT	DP SERIES 5 S/S		DP SERIES 1 BRONZE				
						L-PORT	T-PORT	L-PORT	T-PORT			
	SERIES 5	SERIES 6	SERIES 1/5	SERIES 1	SERIES 5		STRAIGHT	BRANCH		STRAIGHT	BRANCH	
1/4"	5*											
3/8"	10*											
1/2"	12	12	13		14	6.6	7.4	5.2	12	14	8.7	
3/4"	42*	42*	52		42	17	20	13	21	25	16	
1"	73	73*	80	65	70	33	39	24	33	39	24	
1-1/2"	170	170*	190	143	190	79	93	58	79	93	58	
2"	360	360*	400	280	370	149	180	110	149	180	110	
2-1/2"	650				600							
3"	935	935	1,100	700	900	350	415	250	290	345	210	
4"	1,900	1,900	2,400	880	1,650	640	770	465	460	540	340	
6"	4,800		5,600	1,500	3,900	1,550	1,860	1,110	1,050	1,220	790	
8"			10,700	7,400								
10"			17,400									

150# Flanged and Butt Weld, unless indicated otherwise noted (gpm at 1 psi d/p)

VALVE SIZE	MULTI-PORT											
	MP SERIES 5				MP SERIES 4				MP SERIES 1			
	L-PORT	T-PORT		LL-PORT	L-PORT	T-PORT		LL-PORT	L-PORT	T-PORT		LL-PORT
		STRAIGHT	BRANCH			STRAIGHT	BRANCH			STRAIGHT	BRANCH	
1/2"	6.6*	6.6*	5.4*	6.0*	6.6	7.4	5.2	6.6	12	14	8.7	6.6
3/4"	16*	16*	12*	14*	17	20	13	16	17	20	13	16
1"	33	33	21	30	33	39	24	27	33	39	24	27
1-1/4"					32	36	23	26	32	37	23	26
1-1/2"	80	80	49	72	79	93	58	73	79	93	58	73
2"	147	147	89	126	149	180	110	128	149	180	110	128
3"	351	351	212	295	350	415	250	300	200	250	140	180
4"	613	613	368	443	640	770	465	530	365	450	260	340
6"					1,550	1,860	1,110		1,550	1,860	1,110	

*Q (FNPT) ends

Stem Torque

Valve Style/ Series	Valve Size (in.)	As built Torque		Minimum Actuator Sizing vs. Differential Pressure across Seats																		
				0 psig	0 barg	100 psig	6.9 barg	200 psig	13.8 barg	300 psig	20.7 barg	400 psig	27.6 barg	500 psig	34.5 barg	600 psig	41.4 barg	700 psig	48.3 barg			
		in.-lb.	N-m	in.-lb.	N-m	in.-lb.	N-m	in.-lb.	N-m	in.-lb.	N-m	in.-lb.	N-m	in.-lb.	N-m	in.-lb.	N-m	in.-lb.	N-m			
All Series 5 & 6 2-Way & 3-Way	1/2	32	3.6	64	7.2	64	7.2	64	7.2	64	7.2	64	7.2	64	7.2	64	7.2	64	7.2			
	3/4	40	4.5	80	9.0	80	9.0	80	9.0	80	9.0	80	9.0	96	10.8	112	10.8	128	12.7			
	1	58	6.6	116	13.1	116	13.1	116	13.1	150	16.9	185	20.9	220	24.9	trun.						
	1-1/2	154	17.4	308	34.8	308	34.8	440	49.7	580	65.5	715	80.8	trun.	trun.							
	2	182	20.6	364	41.1	364	41.1	635	71.7	910	102.8	1,180	133.3	trun.	trun.							
	2-1/2	288	32.5	576	65.1	576	65.1	1,200	135.6	1,600	180.8	trun.										
	3	430	48.6	860	97.2	860	97.2	1,560	176.3	trun.	trun.											
	4	787	88.9	1,570	177.4	2,650	299.4	trun.	trun.													
6	1,920	217.0	3,840	433.9	7,100	802.3	Use trunnion above 75 psid.															
AF Series 1 & 3	1	58	6.6	116	13.1	116	13.1	116	13.1	150	17.0	185	20.9	220	24.9	255	28.8	288	32.5			
	1-1/2	132	14.9	264	29.8	264	29.8	375	42.4	500	56.5	600	67.8	725	81.9	850	96.1	950	107.4			
	2	154	17.4	308	34.8	308	34.8	440	49.7	580	65.5	715	80.8	850	96.1							
	3	336	38.0	675	76.3	675	76.3	1,400	158.2	1,900	214.7	2,400	271.2	2,900	327.7	3,400	384.2					
	4	432	48.8	860	97.2	860	97.2	1,560	176.3	2,050	231.7	2,540	287.0	3,030	342.4							
	6	1056	119.3	2100	237.3	3950	446.4	Use trunnion above 75 psid.														
MP Series 5	1/2	67	7.57	135	15.3	142	16.0	149	16.8	154	17.4											
	3/4	80	9.04	160	18.1	167	18.9	174	19.7	182	20.6											
	1	154	17.4	307	34.7	322	36.4	337	38.1	358	40.5											
	1-1/2	313	35.4	627	70.9	670	75.7	759	85.8	843	95.3											
	2	491	55.5	981	110.9	1,037	117.2	1,238	139.9	1,388	156.8											
	3	840	94.9	1,679	189.7	2,084	235.5	2,761	312.0	3,268	369.3											
	4	1539	173.9	3,077	349.7	4,114	464.9	5,580	630.5	6,679	754.7											
MP Series 4	1/2, 3/4	77	8.7	144	16.3	144	16.3	144	16.3	144	16.3	144	16.3	144	16.3	144	16.3	144	16.3			
	1	192	21.7	385	43.5	385	43.5	385	43.5	385	43.5	385	43.5	385	43.5	440	49.7	trun.	trun.			
	1-1/2	384	43.4	770	87	770	87	770	87	940	106.2	trun.	trun.									
	2	432	48.8	865	97.7	865	97.7	865	97.7	1,200	135.6	trun.	trun.									
	3	864	97.6	1,730	195.5	1,730	195.5	trun.	trun.													
	4	1,920	216.9	3,840	433.9	3,840	433.9	trun.	trun.													
	6	3,000	339.0	6,000	678.0	8,800	994.4															
MP Series 1	1/2, 3/4	77	8.7	144	16.3	144	16.3	144	16.3	144	16.3	144	16.3									
	1	192	21.7	385	43.5	385	43.5	385	43.5	385	43.5	385	43.5									
	1-1/2	384	43.4	770	87	770	87	770	87	940	106.2	trun.	trun.									
	2	432	48.8	865	97.7	865	97.7	865	97.7	1,200	135.6	trun.	trun.									
	3	576	65.1	1,150	129.9	1,150	129.9	1,620	183	2,100	135.6											
4	864	97.6	1,700	192.1	3,000	339	trun.	trun.														

- Notes:
1. For valves with UHMWPE and RTFE seats, multiply the above values by 1.25
 2. For valves which have S-TEF® or Kynar® seats multiply the above values by 1.56.
 3. For valves with PEEK® seats multiply the above values by 1.7.
 4. Where trunnion is indicated, IMI PBM recommends trunnion mounting the ball to avoid excessive seat loads and stem torques.
 5. For AF Series 1 and 3 stem torques, refer to IMI PBM Sanitary Brochure, LT-34.
 6. CP torque valves assume service at -320°F.
 7. For Series 5 SD, FD, DD valves ins steam service and having RTFE seats, multiply minimum V-TEF/VTFE actuator torques by 1.56.

CP Series 6 These are actuals, not sizing.	As Built Torque		Cryo As Built		0 psig	0 barg	100 psig	6.9 barg	200 psig	13.8 barg	300 psig	20.7 barg	400 psig	27.6 barg	500 psig	34.5 barg	600 psig	41.4 barg	700 psig	48.3 barg	
	in.-lb.	N-m	in.-lb.	N-m	in.-lb.	N-m	in.-lb.	N-m	in.-lb.	N-m	in.-lb.	N-m	in.-lb.	N-m	in.-lb.	N-m	in.-lb.	N-m	in.-lb.	N-m	
1/2	95	11	95	11	95	11	95	11	95	11	95	11	95	11	95	11	101	11	110	12	
3/4	95	11	95	11	95	11	95	11	95	11	95	11	95	11	95	11	101	11	110	12	
1	145	16	160	18	160	18	160	18	160	18	160	18	170	19	193	22	215	24	238	27	
1-1/2	420	47	420	47	420	47	420	47	420	47	420	47	477	54	544	61	611	69	677	76	
2	540	61	840	95	840	95	840	95	840	95	866	98	1013	114	1162	131	1310	148	1458	165	
3	1020	115	1320	149	1320	149	1320	149	1542	174	1984	224	2425	274	2866	324	3307	374	3749	424	
4	Consult IMI PBM Engineering.																				

Testing

- Vacuum Testing
- Cycle Testing
- Shock and Vibration
- Seismic
- Hydrostatic
- Material Test Reports
 - Physical testing
 - Chemical testing

Options

- Trunnion
- Manual Spring Return Handles
- LOX (Cleaned for Oxygen Service)
- Body Cavity Fillers
- Steam Seats (Encapsulated)
- Purge Ports (SIP/CIP)
- Fire Rated, API 607
- Dribble Control Units
- High Alloys
- Fabflex® Manifolds
- Self Cleaning Flushable Ball
- USCG Category A
- ABS Type Approval
- Mechanical & Electro-Polishing
- Direct Mount Actuation
- Positioners
- Fieldbus, AS-i, DeviceNet
- Ball Flats or Purge Holes
- Locking & Ext. Locking Handles
- Internal & External Grounding
- Cylindrical Radius Weld Pads
- V-Balls for Flow Control

Steam Valves

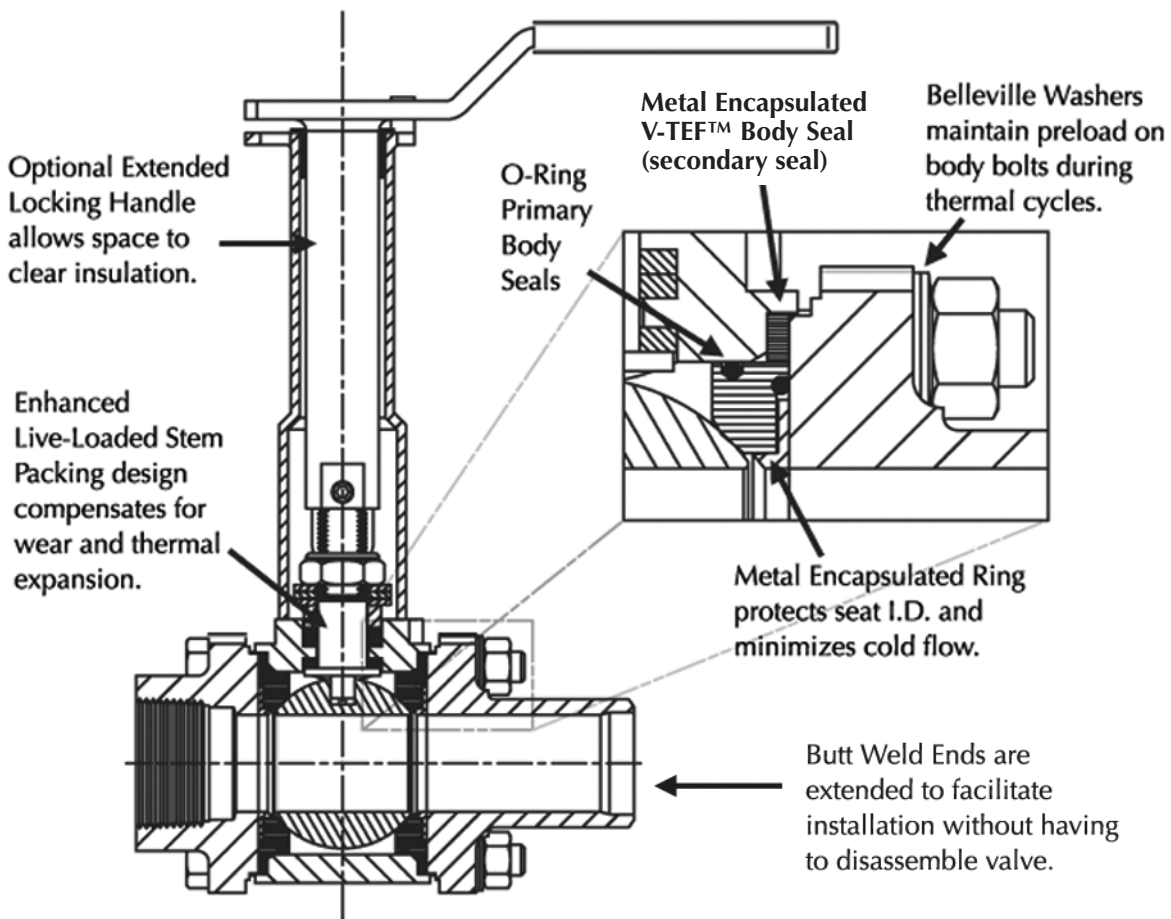

Options

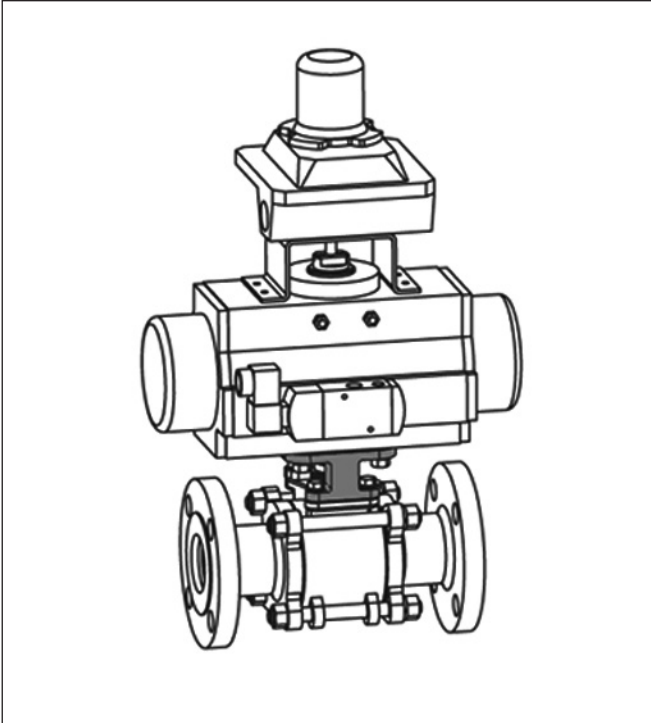

Direct Mount Actuation

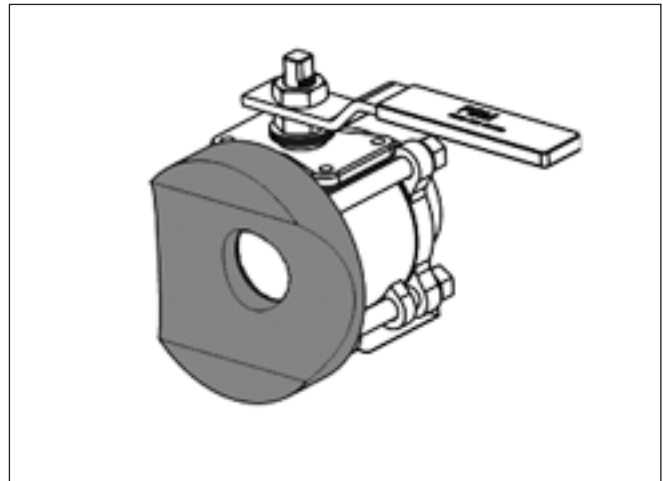

Cylindrical Radius Pad

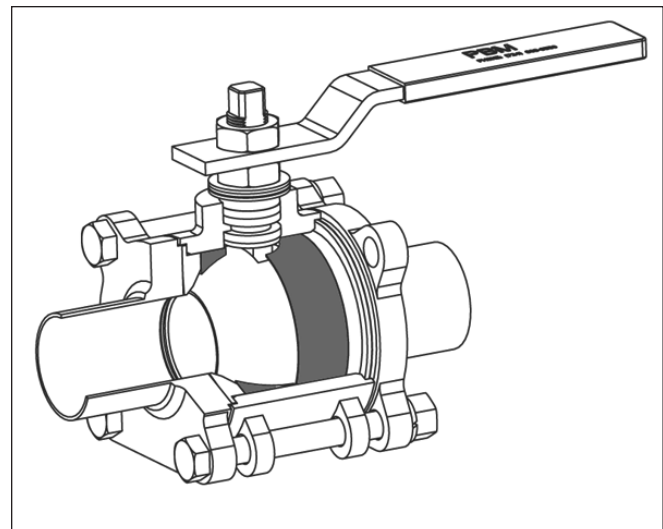

Cavity Fillers

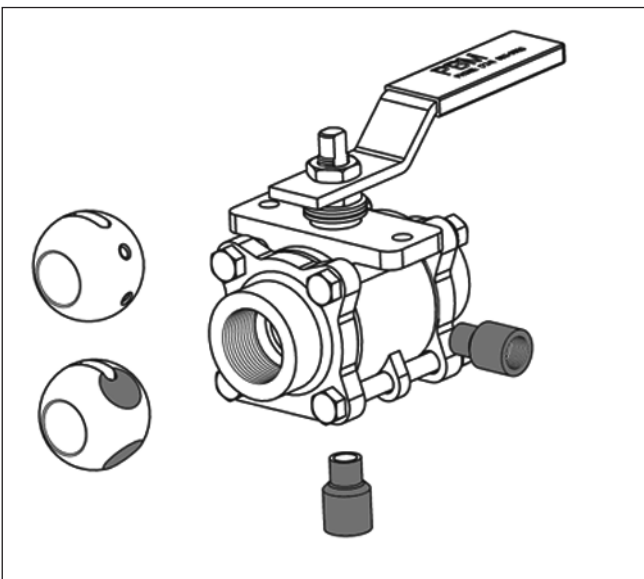

Purge Ports, Milled Flats and Purge Holes

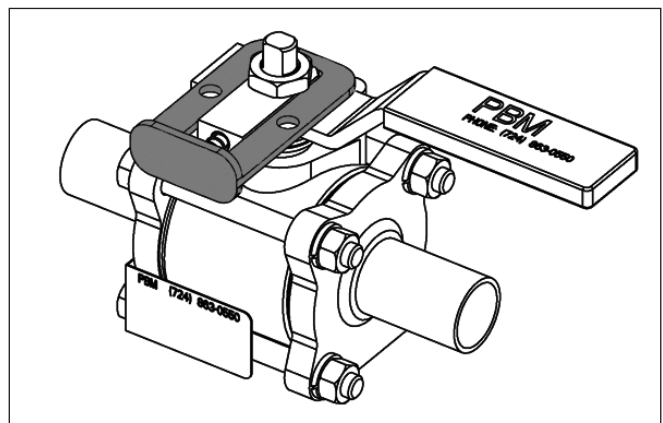

Locking Handle

IMI PBM FLOW PATTERNS

Code (#) Port Style	DIVERTER PORT • 3-way • SIDE ENTRY				DIVERTER PORT • 3-way • BOTTOM ENTRY				
	03 T-90°	04 T-90°	06 T-180°	10 L-90°	14 L-360°	15 L-180°	16 T-90°	17 TT-180°	18 LL-90°
Position A									
Position B									
Position C									
Position D									

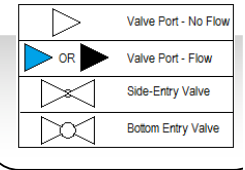

Code (#) Port Style	MULTI-PORT • 3-way • SIDE ENTRY												
	01 T-90°	02 T-90°	03 T-90°	04 T-90°	05 T-180°	06 T-180°	07 T-180°	08 T-180°	09 T-360°	10 L-90°	11 L-180°	12 L-180°	13 L-360°
Position A													
Position B													
Position C													
Position D													

Code (#) Port Style	MULTI-PORT • 3-way • BOTTOM ENTRY					
	14 L-360°	15 L-180°	16 T-90°	17 TT-180°	18 LL-90°	19 L-90°
Position A						
Position B						
Position C						
Position D						

The flow patterns depicted are a birds-eye-view - as though you are looking down on the stem.

Code (#) Port Style	MULTI-PORT • 4-way • BOTTOM ENTRY												
	20 LL-90°	21 LL-180°	22 LL-180°	23 LL-180°	24 LL-180°	25 LL-360°	26 L-360°	27 T-90°	28 TT-180°	29 TT-180°	30 TT-180°	31 TT-180°	32 TT-360°
Position A													
Position B													
Position C													
Position D													

Code (#) Port Style	MULTI-PORT • 4-way • BOTTOM ENTRY				MULTI-PORT • 4-way • SIDE ENTRY							
	33 TT-90°	34 TT-90°	35 TT-90°	36 TT-90°	37 LL-90°	38 L-180°	39 L-360°	40 T-180°	41 -90°	42 T-90°	43 T-90°	
Position A												
Position B												
Position C												
Position D												

Code (#) Port Style	MULTI-PORT • 5-way • BOTTOM ENTRY								52
	44 L-360°	45 LL-180°	46 T-90°	47 TT-90°	48 TT-90°	49 TT-180°	50 TT-360°	51 LL-360°	Y-120°
Position A									
Position B									
Position C									
Position D									

Metal Seats

IMI PBM's Metal Seated Valve Applications include:

- STEAM SERVICE
- HIGH TEMPERATURE / PRESSURE
- ABRASION RESISTANCE
- MODULATING SERVICE



Design Features:

- 1/2" - 4" in Full Bore, CL150 and CL300 standard
- Design capability to manufacture larger sizes and higher pressure classes
- Temps up to 800°F/427°C
- Class V shut-off
- Live-loaded packing assures long maintenance-free operation
- IMI PBM's metal seated valves are fundamentally firesafe
- Valves with weld end fittings can be welded without disassembly.
- Optional patented locking lever handle and complete line of automation and controls
- Complete repair services available - fast turn around on valve repair
- Short lead times on stocked ANSI valves sizes 1/2" through 2"
- SIL-3 capable per IEC 61508
- Extended handles and automation brackets available for higher temperature services.

Specially designed carbide and/or ceramic thermal spray coatings are a valve industry standard. All of the coatings are applied robotically, using the Accuraspray Plume Sensor System, to insure consistently high quality coatings.

CHROME CARBIDE	
TYPICAL COMPOSITION, WT%	
Nickel Chrome	20%
Chrome Carbide	Balance
COATING CHARACTERISTICS	
Bond Strength, PSI	>10,000/690 bar
Hardness	67
Porosity	2%
Max. Service Temperature	800°F/427°C

TUNGSTEN CARBIDE	
TYPICAL COMPOSITION, WT%	
Carbon	3.7%
Iron	0.5%
Nickel	10.0%
Tungsten Carbide	Balance
COATING CHARACTERISTICS	
Bond Strength, PSI	>10,000/690 bar
Hardness	65-58 RC
Porosity	<1%
Max. Service Temperature	800°F/427°C

Coating Options:

Chrome Carbide, 20% Nickel/Chrome

A hard coating that does not oxidize at high temperatures. Provides good abrasion, particle erosion cavitation and fretting resistance in high temperature environments. Good corrosion resistance and sliding properties.

Tungsten Carbide, 10% Nickel

A hard, dense coating to resist high abrasive conditions, as well as particle erosion and fretting while providing the corrosion resistance of nickel with minimal loss of heat resistance.

Coating Testing:

- Bond Strength Tensile Test
- Shear Strength Tensile Test
- Macro Hardness Rockwell Test
- Porosity Determination
- Bond Line Contamination
- Abrasion Wear Testing

Written Specifications

SP, SD SERIES 5

Two-Way, Full Port Ball Valve; Body, ball, stem, and end fitting material shall be 316/316L Stainless Steel, HASTELLOY® C-276, Carbon Steel, Bronze Alloy 922, or other. Valve shall be three-piece "swing-out" body design. Seats and seals shall be V-TEF™ - PTFE material and provide both upstream and downstream bubbletight seal and be adjustable for in-line wear. (For SD Series 5 Only - Seats shall be V-TEF™ - PTFE material with EPR O-ring energizer. Seats shall have 316/316L Stainless Steel encapsulation on ID, provide both upstream and downstream bubbletight seal, and be adjustable for in-line wear. Body seal shall be EPR O-rings with V-TEF™ - PTFE back up seal. Body bolts shall be live loaded with Belleville washers.) Stem packing shall be live loaded V-TEF™ - PTFE. For manual valves, handle shall be 300 series stainless steel with optional lever locking device. Body bolts, nuts, and Belleville washers shall be 18-8 stainless steel. Maximum working pressure to be 900 psig but is limited based on valve size, valve material, and end fitting type. Valves are full vacuum. Valves shall not require disassembly for butt welding. Valves shall be non-firesafe design unless otherwise specified. For fire rated valves to API 607 Edition 4, sizes 1/2" - 3", designate Series 6 (see section "FIRE RATED"). IMI PBM Model Number "SP" or "SD"(Material)(Size)5(End Connection)(Seat & Seal, Cavity Filler, O-Ring Material)

SD Series 5: Two-Way Full Port Steam Ball Valve; Body, ball, stem, and end fitting material shall be 316 stainless steel, HASTELLOY® C-276, Carbon Steel, HASTELLOY® C-22®, bronze alloy 922, or other. Valve shall be three-piece "swing-out" body Seats shall be V-TEF™ - PTFE with EPR O-ring energizer. Seats shall have stainless steel encapsulation on ID, provide both upstream and downstream bubbletight seal and be adjustable for in-line wear. Stem packing shall be live loaded white V-TEF™-PTFE. Body seal shall be EPR o-rings with white V-TEF™-PTFE back up seal. Optional 300 Series s/s 2" stem extension for 4" thick installation. Valves shall not require disassembly for butt welding. Body bolts, nuts, and belleville washers shall be 18-8 stainless steel. Body bolts shall be live-loaded with belleville washers. Maximum working pressure to be 720 PSIG and full vacuum but is limited based on valve size, valve material, and end fitting type. Valves shall be a non-firesafe design. To add automation and controls, see section "Automation and Controls". IMI PBM Model number SD (material)-(size) 5 (end connection)

FT, FD SERIES 5

Flush Tank Bottom Ball Valve; Body, ball, stem, and end fitting material shall be 316/316L Stainless Steel, Hastelloy® C-276, Carbon Steel, Bronze Alloy 922, or other. Weld Pad shall be 316L Stainless Steel or other material (Specify). Valve shall be three-piece "swing-out" body design. Seats and seals shall be V-TEF™ - PTFE material and provide both upstream and downstream bubbletight seal and be adjustable for in-line wear. (For FD Series 5 Only - Seats shall be V-TEF™ - PTFE material with EPR O-ring energizer. Seats shall have 316/316L Stainless Steel encapsulation on ID, provide both upstream and downstream bubbletight seal, and be adjustable for in-line wear. Body seal shall be EPR O-rings with V-TEF™ - PTFE back up seal. Body bolts shall be live loaded with Belleville washers.) Stem packing shall be live loaded V-TEF™ - PTFE. For manual valves, handle shall be 300 series stainless steel with optional lever locking device. Body bolts, nuts, and Belleville washers shall be 18-8 stainless steel. Valves shall be non-firesafe design unless otherwise specified. For fire rated valves to API 607 Edition 4, sizes 1/2" - 3", designate Series 6 (see section "FIRE RATED").

To add automation and controls, see section "AUTOMATION AND CONTROLS".

IMI PBM Model Number "FT" or "FD"(Material)(Size)5(End Connection)(Seat & Seal, Cavity Filler, O-Ring Material)

AF SERIES 1

Angle Stem Flush Tank Bottom Ball Valve; Body, ball, stem, and end fitting material shall be 316/316L Stainless Steel, Hastelloy® C-276, Carbon Steel, Bronze Alloy 922, or other. Weld Pad shall be 316L Stainless Steel or other material (Specify). Valve shall be two-piece design. Seats and seals shall be RTFE material and provide both upstream and downstream bubbletight seal and be adjustable for in-line wear. Stem packing shall be live loaded RTFE. For manual valves, handle shall be 300 series stainless steel with optional lever locking device. Body bolts and nuts shall be 18-8 stainless steel. Valves shall be non-firesafe design unless otherwise specified. For fire rated valves to API 607 Edition 4, sizes 1" - 6", designate Series 3 (see section "FIRE RATED"). To add automation and controls, see section "AUTOMATION AND CONTROLS".

IMI PBM Model Number AF(Material)(Size)1(End Connection)(Seat & Seal, Cavity Filler, O-Ring Material)

CP SERIES 6, 2-Way Firesafe CRYOGENIC Valve

Uni-directional Flow and Vented Ball; Material shall be 316/316L Stainless Steel or other material (Specify). Seats and seals shall be V-TEF™, seat and stem packings shall be live-loaded. Valve shall be uni-directional with body markings for flow direction and upstream vent hole in ball. End connections available include female NPT, 150# ANSI RF flanged, extended butt weld for Sch 40 pipe and extended socket weld ends. Extended ends do not require valve to be disassembled for welding. For manual valves, handle shall be 300 series stainless steel. Maximum working pressure to be 720 psig CWP and temperatures from ambient to -320 degrees F (-200 degrees C). Valve shall be cleaned for oxygen service and shall meet or exceed leakage performance per MSS SP-134.

Optional automation (Pneumatic or electric), mechanical and electro-polishing surfaces, sizes ½-inch through 4-inch

IMI PBM Model Number CP(Material)(Size)(Series)(End Connection)(Seat & Seal, Cavity Filler, O-Ring Material)

DP, DD SERIES 5

Three-Way, Diverter Port Ball Valve; Body, ball, stem, and end fitting material shall be 316/316L Stainless Steel, Hastelloy® C-276, or other. Valve shall be three-piece design. Seats and seals shall be V-TEF™ - PTFE material and provide both upstream and downstream bubbletight seal and be adjustable for in-line wear. (For DD Series 5 Only - Seats shall be V-TEF™ - PTFE material with EPR O-ring energizer. Seats shall have 316/316L Stainless Steel encapsulation on ID, provide both upstream and downstream bubbletight seal, and be adjustable for in-line wear. Body seal shall be EPR O-rings with V-TEF™ - PTFE back up seal. Body bolts shall be live loaded with Belleville washers.) Stem packing shall be live loaded V-TEF™ - PTFE. For manual valves, handle shall be 300 series stainless steel with

optional lever locking device. Body bolts, nuts, and Belleville washers shall be 18-8 stainless steel. Maximum working pressure to be 900 psig but is limited based on valve size, valve material, and end fitting type. Valves are full vacuum. Specify IMI PBM Flow Pattern. To add automation and controls, see section "AUTOMATION AND CONTROLS".

IMI PBM Model Number "DP" or "DD"(Material)(Size)5(End Connection)(Seat & Seal, Cavity Filler, O-Ring Material)(IMI PBM Flow Pattern)

AN SERIES 1

Two-Way, ANSI Flanged Full Port Ball Valve; Body, ball, stem, and end fitting material shall be 316/316L Stainless Steel, Hastelloy® C-276, Carbon Steel, Bronze, Aluminum Bronze, or other. Valve shall be two-piece "split body" design. Seats and seals shall be RTFE material with Viton® or EPR O-Ring body seal. Seats shall provide both upstream and downstream bubbletight seal and be adjustable for in-line wear. Stem packing shall be live loaded RTFE. End fittings shall be ANSI 150# flanged per ANSI B16.5 and face to face dimension shall conform to ASME B16.10 Long Pattern. For manual valves, handle shall be 300 series stainless steel with optional lever locking device. Body bolts and nuts shall be 18-8 stainless steel. Maximum working pressure to be 285 psig but is limited based on valve size, valve material, and end fitting type. Valves are full vacuum. Valves shall be 100% tested per ASME / ANSI B16.34. Valves shall be non-firesafe design unless otherwise specified. For fire rated valves to API 607 Edition 4, sizes 1/2" - 6", designate Series 3 or Series 6 (see section "FIRE RATED"). To add automation and controls, see section "AUTOMATION AND CONTROLS".

IMI PBM Model Number AN(Material)(Size)1(End Connection)(Seat & Seal, Cavity Filler, O-Ring Material)

AN SERIES 5

Two-Way, ANSI Flanged Full Port Ball Valve; Body, ball, stem, and end fitting material shall be 316/316L Stainless Steel or Carbon Steel. Valve shall be two-piece "split body" design. Seats and seals shall be V-TEF™ - PTFE material with Viton® or EPR O-Ring body seal. Seats shall provide both upstream and downstream bubbletight seal and be adjustable for in-line wear. Stem packing shall be live loaded V-TEF™ - PTFE. End fittings shall be ANSI 150# flanged per ANSI B16.5 and face to face dimension shall conform to ASME B16.10 Long Pattern. For manual valves, handle shall be 300 series stainless steel with optional lever locking device. Body bolts and nuts shall be 18-8 stainless steel. Maximum working pressure to be 740 psig but is limited based on valve size, valve material, and end fitting type. Valves are full vacuum. Valves shall be 100% tested per ASME / ANSI B16.34. Valves shall be non-firesafe design unless otherwise specified. For fire rated valves to API 607 Edition 4, sizes 1/2" - 4", designate Series 6 (see section "FIRE RATED").

To add automation and controls, see section "AUTOMATION AND CONTROLS".

IMI PBM Model Number AN(Material)(Size)5(End Connection)(Seat & Seal, Cavity Filler, O-Ring Material)

MP SERIES 1, 4 AND 5

Three, Four, or Five Way Multi-port Ball Valve; Body, ball, stem, and end fitting material shall be 316/316L Stainless Steel, Carbon Steel, Hastelloy® C-276, or other (Series 1 only - Ductile Iron and Bronze). Valve shall have 4 or 5 V-TEF™ - PTFE (Series 1 only - RTFE) seats and seals and provide bubbletight seal and be adjustable for in-line wear. Stem packing shall be live loaded V-TEF™ - PTFE (Series 1 only - RTFE). For manual valves, handle shall be 300 series stainless steel (Series 4 or 5 - optional lever locking device). Body bolts and nuts shall be 18-8 stainless steel. Maximum working pressure to be 720 psig (Series 1 only - 400 psig) but is limited based on valve size, valve material, and end fitting type. Valves are full vacuum. Specify IMI PBM Flow Pattern for 3, 4, or 5-way valve. To add automation and controls, see section "AUTOMATION AND CONTROLS".

IMI PBM Model Number MP(Material)(Size)(Series)(End Connection)(Seat & Seal, Cavity Filler, O-Ring Material)(IMI PBM Flow Pattern)

TI SERIES 5

Transmitter Isolation Ball Valve; Body, ball, stem, and end fitting material shall be 316/316L Stainless Steel, Hastelloy®, Titanium, or others with 1" or 2-1/2" port diameter. Tank side flange to accommodate both standard ANSI 3", 150# flange drilling and a 25 to 27 degree offset flange pattern. Instrument side flange shall be drilled to accommodate a standard ANSI 3", 150# flange drilling. Valve shall have a 1/4 turn manual 300 series stainless steel handle with lever locking device. Valve shall have four (4) 1/4" FNPT Purge Ports, each with a 1/4" MNPT plug made from the same material as the valve body. Seats and seals shall be V-TEF™ - PTFE material with VTFE O-ring.

IMI PBM Model Number TI(Material)(Size)5(End Connection)(Seat & Seal, Cavity Filler, O-Ring Material)

FIRE RATED (SERIES 3 AND SERIES 6)

Two-Way, Industrial Ball Valve; SP Series 6 and FT Series 6, 1/2" - 3", AN Series 6, 1/2" - 4", AN Series 3 and AF Series 3, 1" - 6". Valve design shall be tested and comply with criteria set forth in API-607 Edition 4. Valve body bolts to be fully encapsulated. Valve design is non-Adjust-O-Seal®. Body seals shall be graphite material isolated from product stream under normal operating conditions by O-ring seals. Upon sublimation of seat and seal material in the event of a fire condition, a metal back up seat shall seal the valve at leakage rates in accordance with API-607, Edition 4. Maximum working pressure to be 720 PSIG and full vacuum but is limited based on valve size, valve material, and end fitting type.

IMI PBM Model Number (Product)(Material)(Size)(Series)(End Connection)(Seat & Seal Material)

AUTOMATION AND CONTROLS

Direct Mount Automated Ball Valves; Valves as specified in "Manual Valves" section with the addition of a "Direct Mount" double acting or spring return pneumatic actuator. Actuator shall be of the double opposing piston, rack and pinion design with bidirectional pinion travel stops and hard anodized aluminum oxide body with co-deposited fluoropolymer. End caps to be polyester powder coated with 300 series stainless steel fasteners. Mounting bracket shall be stainless steel and valve stem shall insert directly into actuator drive adapter. Actuators shall be sized utilizing a 100% safety factor. Specify supply air pressure at actuator (60 or 80 PSIG). IMI PBM Model Number starts with "PA". Electric actuators, limit switches, positioners, solenoids, and field bus accessories; Specify according to all statutory and regulatory requirements. Include NEMA rating Requirements and electrical current.

Instrument Valves

IMI PBM's instrument valve is used for process isolation or isolation of pressure gauges, orifice plates, flush rings and various measurement instruments. Valves are designed to ASME B16.34. They offer a higher performance solution to needle valves.

SIZES

- 1/2" and 3/4" sizes with 0.41 bore

PRESSURE CLASS

- 1/4" - 3/4" Up To ANSI CL2500 (CL1500 standard)

MATERIALS

- Stainless Steel
- Duplex Stainless Steel
- Carbon Steels
- Monel®
- Hastelloys®
- Others Available

END CONNECTIONS

- Thread Pipe, male or female Flanged
- Buttweld (tube or pipe)
- Socket Weld (male or female)
- Compression
- Instrument Adapter Flange
- Others Available

FEATURES

- Quarter Turn Operation
- Optional Extended Handle with lock out
- Bleed or Gauge Ports Available
- Soft and Metal Seated Designs
- Locking Handle Standard
- Welded Body
- API-622 Low-E Stem Packing Standard
- Rodable in 1/4" - 3/4"
- SIL-3 Capable per IEC 61508

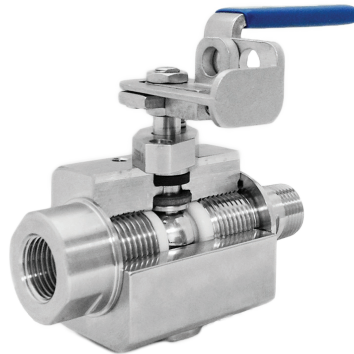

SEATING

- V-TEF™ Seats - 350°F, 176°C
- S-TEF® Seats - 400°F, 204°C
- PEEK® Seats - 500°F, 260°C
- Stellite® Ball & Seats, 800°F, 427°C
- Tungsten or Chrome Carbide Coated S/S Ball & Seats, < 800°F, 427°C

Notes:

IMI PBM can comply with API-6D if specified.

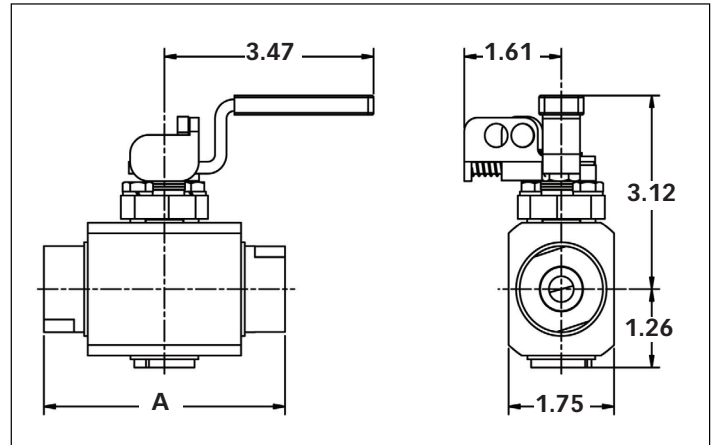

2-WAY VALVE End Fitting	A inches	A mm
Ext. Male NPT	6.50	165
Male NPT	4.75	121
Female NPT	4.00	102
Ext. Female Socket Weld	6.50	165
Buttweld for Sch. 40 Pipe	6.50	165
Buttweld for Tube	6.50	165

Notes:
Dimensions shown for 1/2" valves only.
Design is rotable with rod out tool.

PACKING

- Die molded Graphite (High Temperature) V-TEF™ or S-TEF®
- API-622 Low-E Stem Packing Standard in 1/2" and 3/4" sizes with .41 bore. It is optional in larger sizes.

TESTING AND DOCUMENTATION

- MTR (Material Test Reports)
- PMI (Positive Material Identification)
- LP (Liquid penetrant)
- Radiographic examination
- Pressure testing per API 598
- Magnetic particle examination
- Ultrasonic examination

IMI PBM's New Style Instrument Valves are Tested & Proven to the API 622 Standard

What makes IMI PBM valves API 622?

IMI PBM's Instrument (IM) new style valves standardize on a product offering with API 622 packing which certifies IMI PBM valves for low emission technology.

The API 622 packing features:

- Average stem packing leakage ≤ 10 ppmv for the duration of the test (100 ppm allowable)
- API-607 fire tested
- Successfully passed API-622 testing, test report available upon request.

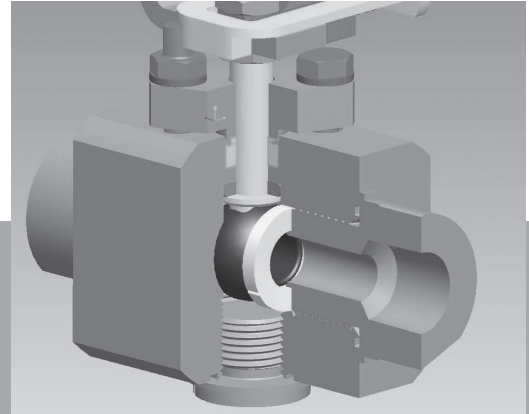

Double Block & Bleed Valves

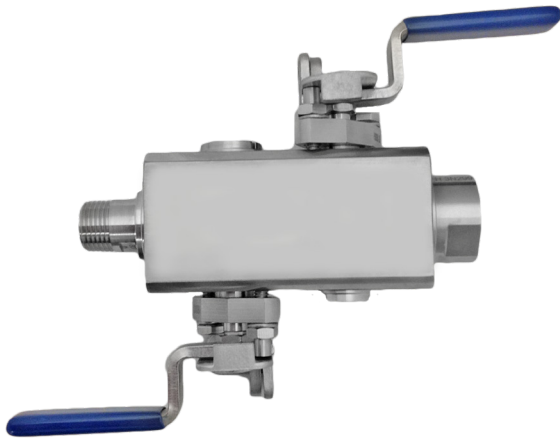

**1/2" CL1500
DOUBLE BLOCK AND
BLEED VALVE
with compression
ends and
locking lever
handles**

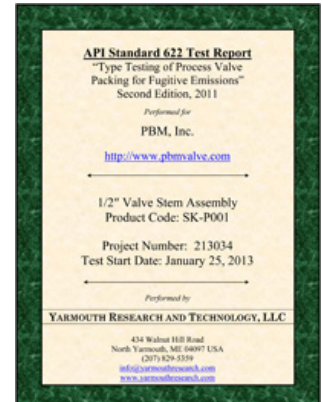

DBB VALVE End Fitting	A in.	A mm	B in.	B mm
Extended Male NPT	8.25	210	4.13	105
Male NPT	6.50	165	3.25	83
Female NPT	5.75	146	2.88	73
Ext. Female Socket Weld	8.25	210	4.13	105
Buttweld for Sch. 40 Pipe	8.25	210	4.13	105
Buttweld for Tube	8.25	210	4.13	105

Notes:
Dimensions shown for 1/2" valves only.
Design is rodable with rod out tool.

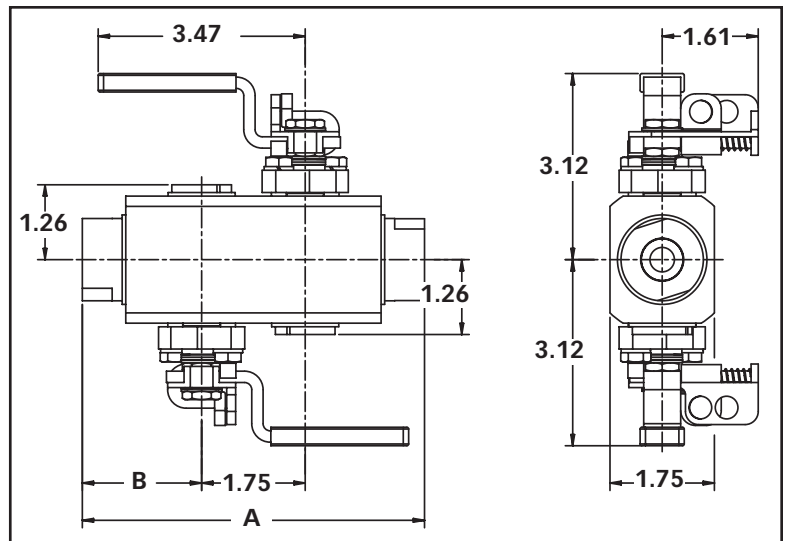

Bolted Instrument Valves

IMI PBM's bolted Instrument Valve design allows end connection design and fabrication flexibility. It is available in a wide range of materials for a variety of temperature and pressure classes to meet your most stringent process applications.

FEATURES

- Full and Reduced Port Designs
- Customizable End Connections
- Quarter Turn Operation
- Bleed or Gauge Ports Available
- Bolted Body
- API-607 Fire Rated
- Braided Graphite Packing
- API-622 Low-E Stem Packing Standard
- Gear Operator recommended for 1-1/2" and above.

SIZES

- 1/2" - 2" CL600, CL900 and CL1500

SEATING

- V-TEF™ Seats: 350°F (176°C)
- S-TEF® Seats: 400°F (204°C)
- PEEK® Seats: 500°F (260°C)
- Stellite® Ball & Seats: 800°F (427°C)
- Tungsten or Chrome Carbide Coated S/S Ball & Seats: 800°F (427°C)

Size	Ends	Units	A		D		E		F		G		H	
			Overall Length		CL to Bottom of Valve (2-Way)		Distance to Top of Valve		Body Width without Ends		Handle Radius		CL to Locking Mechanism	
			CL600	CL1500	CL600	CL1500	CL600	CL1500	CL600	CL1500	CL600	CL1500	CL600	CL1500
1/2" DN 15	Flanged	in (mm)	6.5 (165)	8.5 (216)	1.72 (44)		5.2 (132)		2.4 (61)		3.47 (88)		1.61 (41)	
	Female NPT	in (mm)	4.75 (121)											
	Others	in (mm)	8.5 (216)											
3/4" DN 20	Flanged	in (mm)	7.5 (191)	9 (229)	2.33 (59)		3.96 (101)		3.75 (95)		5 (127)		2.08 (53)	
	Female NPT	in (mm)	5.5 (140)											
	Others	in (mm)	9 (229)											
1" DN 25	Flanged	in (mm)	8.5 (216)	10 (254)	2.92 (74)		5.2 (132)		4.5 (114)		8.81 (224)		2.57 (65)	
	Female NPT	in (mm)	6 (152)											
	Others	in (mm)	10 (254)											
1-1/2" DN 40	Flanged	in (mm)	9.5 (241)	12 (305)	2.82 (72)	4.17 (106)	5.76 (146)	7.18 (182)	5.38 (137)	7.5 (191)	11.8 (300)	12 (305)	N/A	
	Female NPT	in (mm)	6.5 (165)	7.5 (191)										
	Others	in (mm)	12 (305)											
2" DN 50	Flanged	in (mm)	11.5 (292)	14.5 (368)	3.42 (87)	4.82 (122)	6.13 (156)	7.43 (189)	6.25 (159)	8 (203)	11.8 (300)	12 (305)	N/A	
	Female NPT	in (mm)	8 (203)	10 (254)										
	Others	in (mm)	14.5 (368)											

The high temperature valve version consists of carbide coating on the ball and seats.

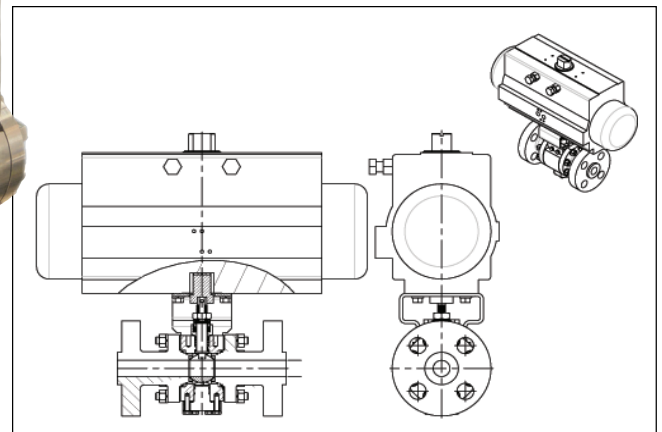
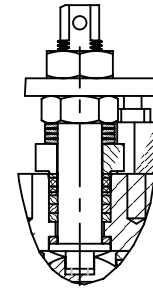
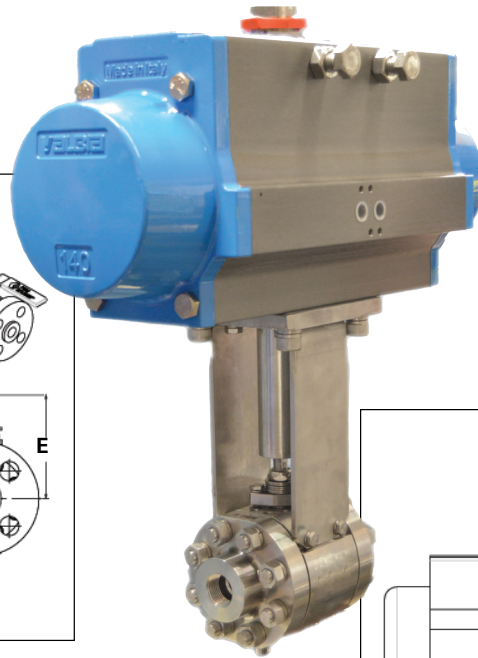
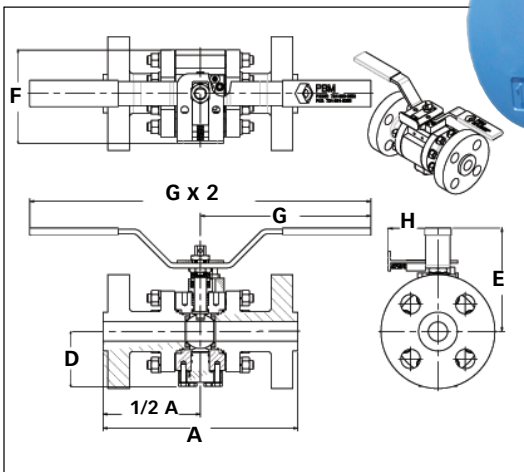

Bolted Double Block & Bleed Valves

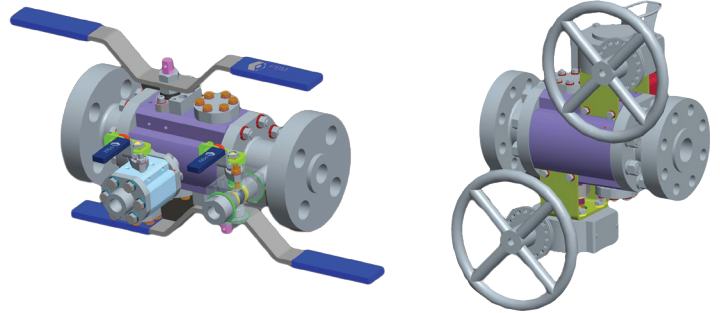
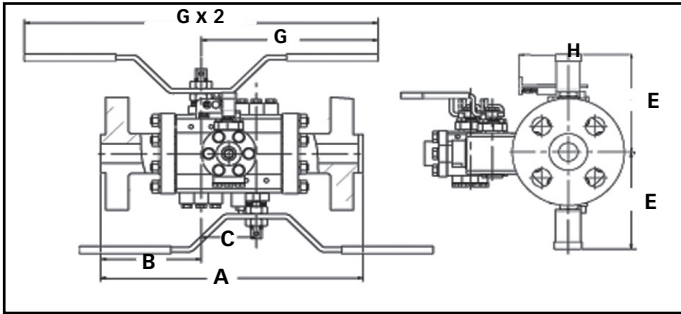

Size	Ends	Units	A		B		C		E		G		H			
			Overall Length		Q to End		Ball Separation		Distance to Top of Valve		Body Width w/o Ends		Handle Radius		Q to Locking Mechanism	
			CL600	CL1500	CL600	CL1500	CL600	CL1500	CL600	CL1500	CL600	CL1500	CL600	CL1500	CL600	CL1500
1/2" DN 15	Flanged	in (mm)	8.25 (210)	10.25 (260)	3.25 (83)	4.25 (108)	1.75 (44)		5.2 (132)		2.4 (61)		3.47 (88)		1.61 (41)	
	Female NPT	in (mm)	6.5 (165)		2.375 (60)											
	Others	in (mm)	10.25 (260)		4.25 (108)											
3/4" DN 20	Flanged	in (mm)	9.75 (248)	11.25 (286)	3.75 (95)	4.5 (114)	2.25 (57)		3.96 (101)		3.75 (95)		5 (127)		2.08 (53)	
	Female NPT	in (mm)	7.75 (197)		2.75 (70)											
	Others	in (mm)	11.25 (286)		4.5 (114)											
1" DN 25	Flanged	in (mm)	11.25 (286)	12.75 (324)	4.25 (108)	5 (127)	2.75 (70)		5.2 (132)		4.5 (114)		8.81 (224)		2.57 (65)	
	Female NPT	in (mm)	8.75 (222)		3 (76)											
	Others	in (mm)	12.75 (324)		5 (127)											
1-1/2" DN 40	Flanged	in (mm)	13.25 (337)	15.75 (400)	4.75 (121)	6 (152)	3.75 (95)		5.76 (146)	7.18 (182)	6 (152)	7.5 (191)	12 (305)		N/A	
	Female NPT	in (mm)	10.25 (260)		3.25 (83)											
	Others	in (mm)	15.75 (400)		6 (152)											
2" DN 50	Flanged	in (mm)	15.25 (387)	18.5 (470)	5.75 (146)	7.25 (184)	3.75 (95)		6.13 (156)	7.43 (189)	6.75 (171)	8 (203)	12 (305)		N/A	
	Female NPT	in (mm)	11.75 (298)		4 (102)											
	Others	in (mm)	18.5 (470)		7.25 (184)											

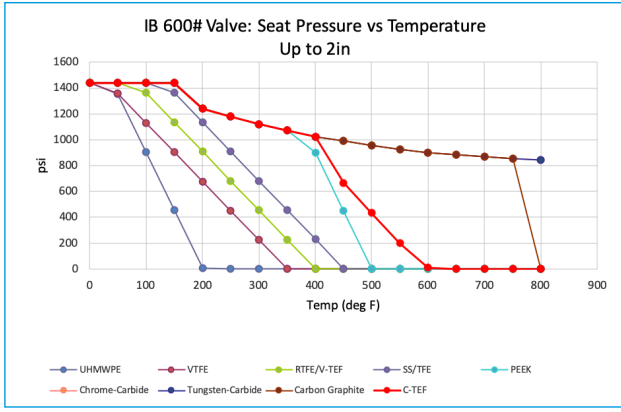
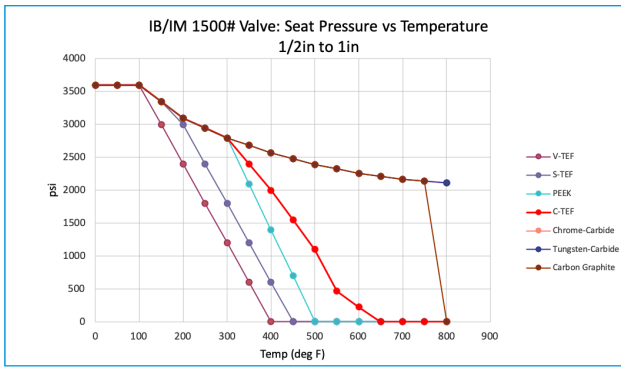
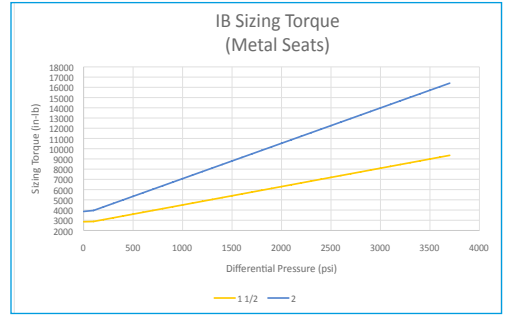
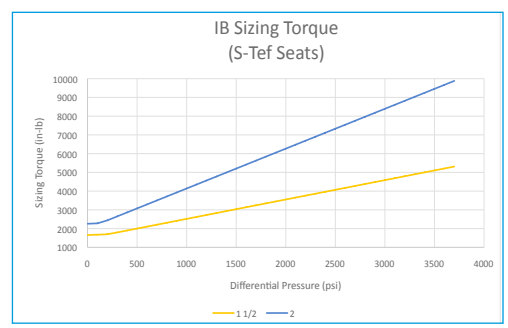
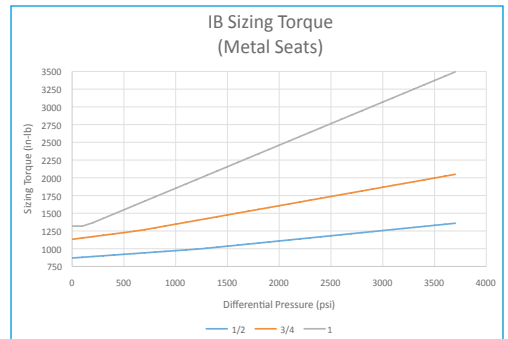
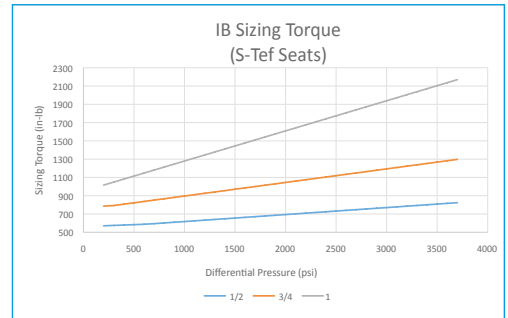

BOLTED INSTRUMENT VALVES PRESSURE/TEMPERATURE AND TORQUE CHARTS

— Transmitter Isolation Valves

IMI PBM Transmitter Isolation Valves are valves used to isolate media in a tank from a pressure/level transmitter. The valve when in the open position creates a communication between the media in the tank and the transmitter. The valve is only closed when the transmitter needs to be isolated for service.

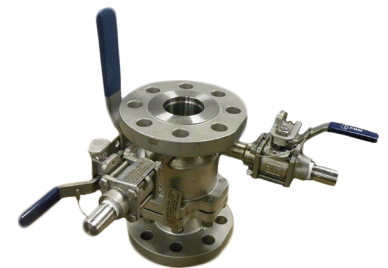
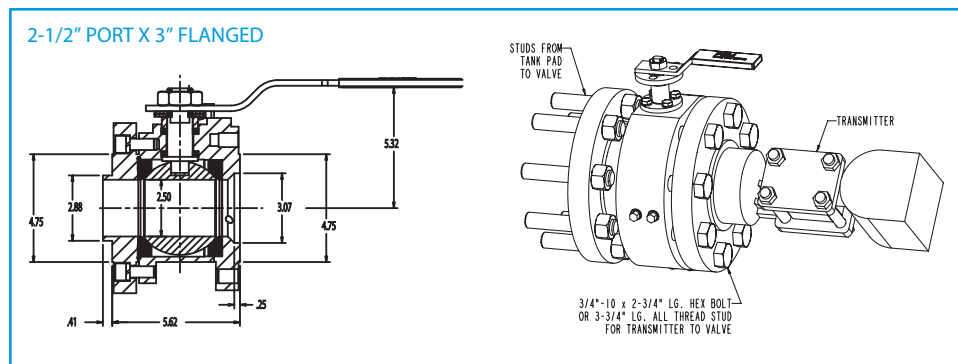
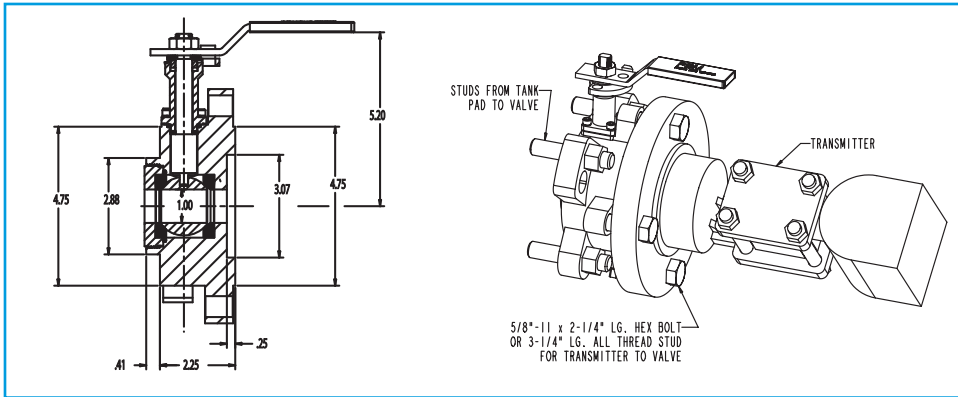

Full or True Bore® Port ANSI Style Transmitter Isolation Valves provide value to the customer.

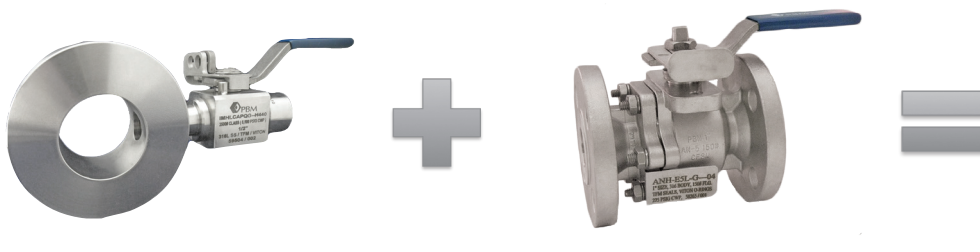

Transmitter Isolation Valves CL300, CL600

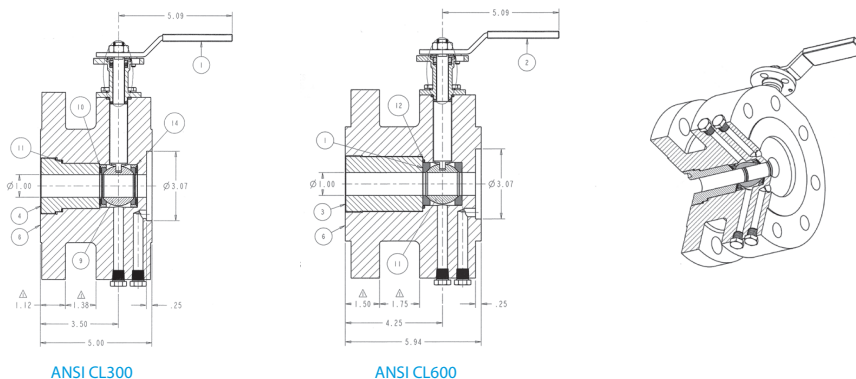

**Pressure Classes: 150-600
 Sizes: 1x2, 1x3, 2.5 x 3 Inch
 (ball port size x flange size)
 Any Materials, Temps <800°F
 Purge/Cal Port Sizes: 1/4 or 1/2 inch
 FNPT (2 or 4 ports available)
 Make to Order. Custom
 configurations available.**

Fabflex® Instrumentation Valve Manifolds

IMI PBM's Valve Manifolds have temperatures that range from 300° to 600° F, 149 to 316°C with pressures from 150 to 400 psig, 10 to 28 barg. A refinery uses these manifolds for measuring as well as level indication.

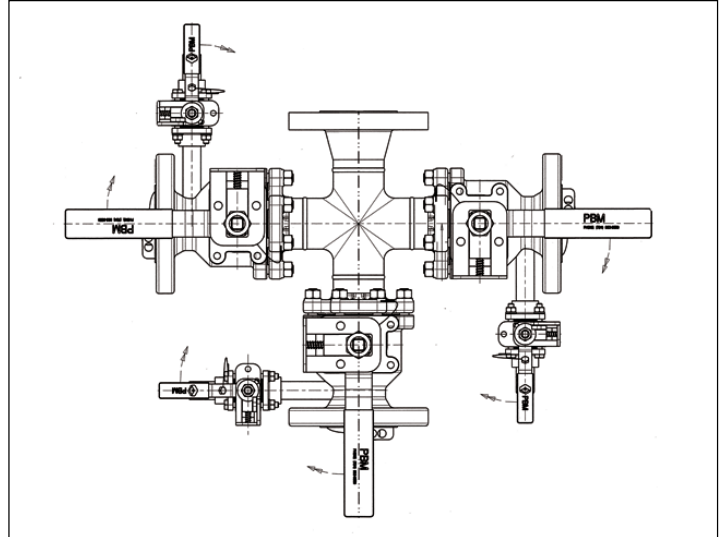

Fabflex® Fabricated Manifold Solution:

- Custom IMI PBM Fabflex® manifold design for multiple instrumentation mounts.
- Custom manifold design to optimize space utilization.
- Factory fabricated in a controlled manufacturing environment to ensure high quality welding fabrication process.
- Individual valves fabricated "into" the manifold eliminating many emission leak paths to improve the overall EPA rating of the system.
- Field installation simplified into bolting up one flange and installing the transmitters, transducers or other instrumentation.



Flush Rings/Bleed Rings with Integral Valve

Flush rings and Bleed rings to customer material and pressure class specifications designed to fit between standard flanges using conventional flange gaskets. Integral ball valve allows venting purging, sampling and instrument isolation.

Sizes:

- 2" width standard
- Consult IMI PBM for additional sizes.

Materials:

- Stainless Steel
- Duplex
- Hastelloy®
- Others

Features:

- Integral code-welded valve for flushing purging and instrument isolation.

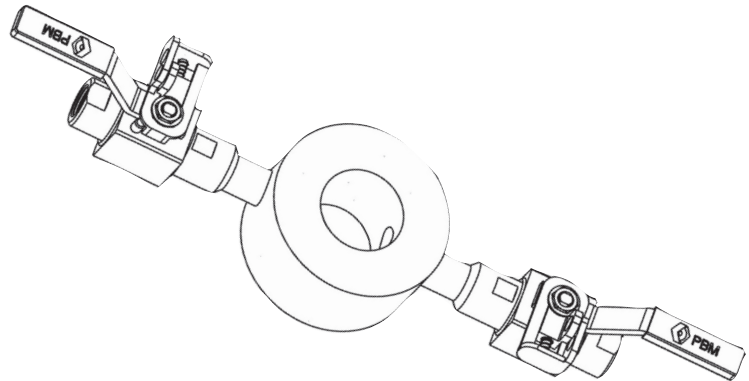
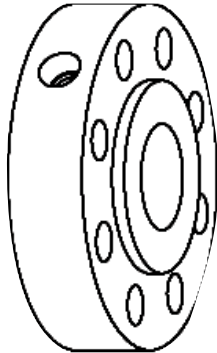

Sampling Tank Bottom Valves

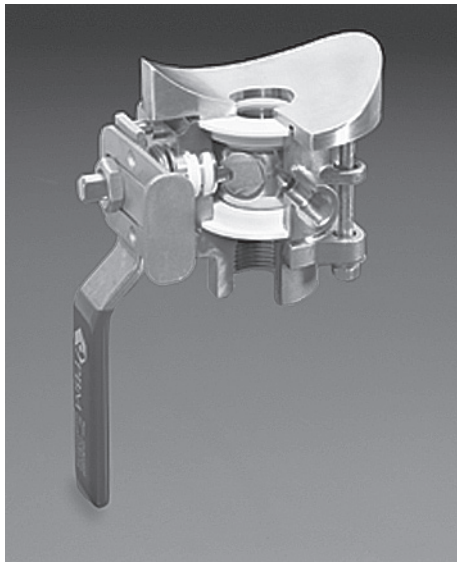

Sample process media quickly and easily with IMI PBM's Sampling Valve. Special pad design minimizes dead space. Easy CIP with Purge Ports and Milled Ball Flats ensures reliable samples. Valve can be shipped pre-mounted to piping for easy installation. Ideal for heavy duty and sanitary applications. Manual valves standard.

Sizes:

- 1/2" - 2"

Materials:

- 316 & 316L S/S
- Hastelloy®
- Titanium
- Others

Options:

- Actuation
- Steam
- Polishing

Cryogenic Ball Valves

IMI PBM Cryogenic valves have a unique design that provides superior performance through cooling and heating cycles. The valves meet leakage criteria per MSS SP-134. Fire tested to API-607. "CN" series split body ANSI flanged Cryogenic valves are also available.

- Sizes 1/2" - 4" Consult IMI PBM for additional sizes.
- Temperatures from 400°F (205°C) down to -320°F (-200° C)
- **Live-loaded** stem packings
- Fire safe to API 607
- Designed & Tested in accordance with ASME B31.1 and B16.34.
- Materials of construction: stainless steel, other materials available
- Pressures to 720 psi CWP (ANSI CL300)
- Cleaned for oxygen service
- Quarter turn operation
- Locking lever handle or optional oval locking handwheel
- Automation available
- V-TEF™ seats/graphite seals
- Internal and external grounding
- Uni-directional flow and vented ball
- Valve meets or exceeds leakage performance per MSS SP-134
- Optional API-622 Low-e Packing (cannot be lox cleaned)



"CP" Series 2-Way Cryogenic Valves

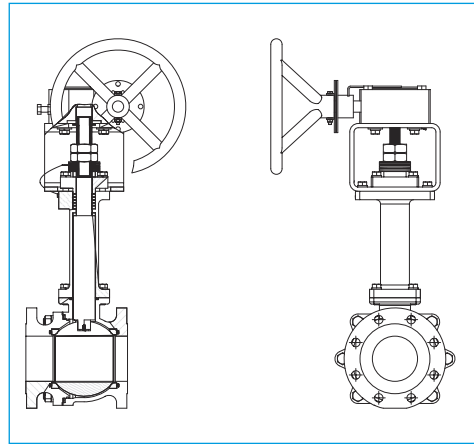
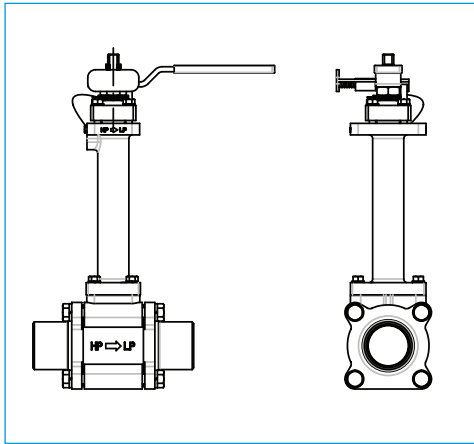

"CD" Series Diverter Cryogenic Valves

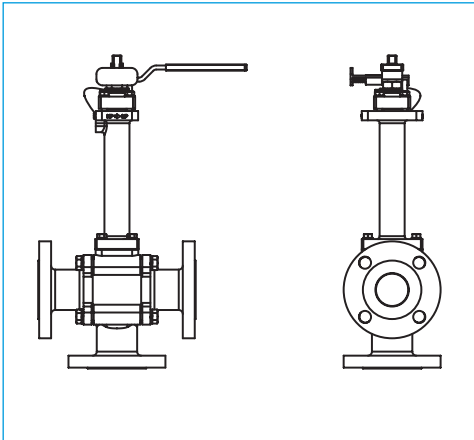

"CN" Series ANSI Cryogenic Valves

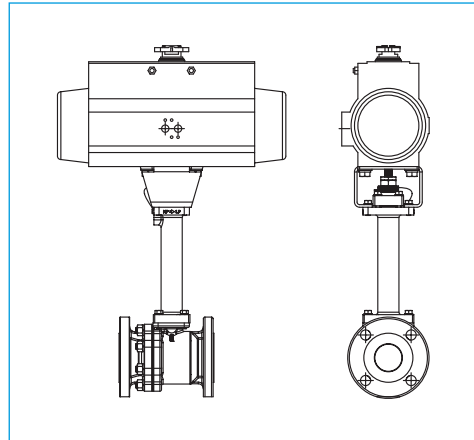

Actuator Features



Nominal Values:

Pressure rating of 120 psig (8 barg). Standard temperature range is -4°F (-20°C) to 185°F (85°C). High temperature range is -4°F (-20°C) to 302°F (150°C). Low temperature range is -40°F (-40°C) to 185°F (85°C). Pre-lubricated for life of actuator on assembly. Fully tested on manufacture 100%.

Rotation adjustment 0-90°

From MOD. 52 up to 200

- Standard + or - 5° in both clockwise and counterclockwise direction by means of adjusting screws outside the internal air supply chambers
- Standard visual position indicators

MOD. 270

- Standard + or - 5° in counterclockwise direction by means of adjusting screws in caps
- Kit for + or - 5° in clockwise direction available on request

External connection

- Namur pinion mounting
- Namur solenoid valve mounting
- Bottom of pinion according to ISO 52-DIN 3337
- Optional Beacon Indicator

Operating Pressure

Range - 40 psig (2.8 barg) to 120 psig (8 barg)

Operating Media

Clean, dry air or clean, dry, non-corrosive gas

Stroke

90 degrees standard

Steel pinion

- Nickel-plated for resistance to corrosion
- Stainless steel (optional) for corrosive environments
- Anti-blowout design

Body manufactured from extruded aluminum UNI 6060

- Hard-coat anodized as standard finish 45-50 (micron)
- Good wear resistance
- Bore finished to high standard to ensure low friction and long life

Seals

- NBR standard
- Viton high temperature (optional)
- HNBR low temperature (optional)

Refer to Series "C" IMI PBM Actuator Brochure for dimensions and technical information.

Use IMI PBM's 2-Way Control Valves in industrial and sanitary throttling or shearing applications to accurately control the flow of liquids or thick media. These valves feature characterized balls with various port shapes, including "V."
Manual valve standard.

Control Valves

Sizes:

- 1/2" - 6"

Materials:

- 316 & 316L S/S
- Hastelloy®
- Others

Options:

- Actuation
- 30°, 45°, 60° V Angle (Others Available)
- Slotted
- Locking Handle
- Polishing & Electropolishing
- Automation

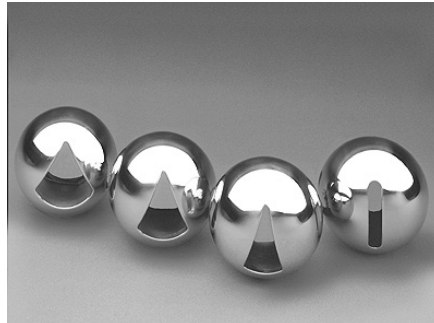

Positioners

- Gauges/No gauges
- 4-20 mA (Electro-pneumatic)
- 3-15 psi (pneumatic)
- Weatherproof, explosion proof
- Proximity, Mechanical Switches
- Solid State Sensors
- Flat or Domed Indicator



Electric Actuators

- Weatherproof, explosion proof
- Modulating or On/Off
- 2, 3, or 4 position
- Battery back-up
- Communication Bus interfaces available
- Auxiliary Limit Switches
- Motor Brake
- Handwheel override
- Potentiometers
- AC or DC

Solenoids

Features:

- Compact spool valve with threaded port direct mounts to actuator.
- All exhaust ports are pipeable, providing better protection against harsh environments.
- Standard manual override
- DIN, weatherproof and explosion proof solenoids available
- Single and dual coil solenoid constructions
- Mountable in any position

Position Indicators



Options:

- Weatherproof, Explosion proof
- Mechanical or Proximity Switches
- Fieldbus
- DeviceNet
- Visual Indication
- AS-i
- ATEX, IEC, CSA, NEMA, etc.





www.pbmvalve.com

IMI PBM

1070 Sandy Hill Road,
Irwin, PA 15642 USA

Tel: +1 800 967 4PBM / 724 863 0550

Fax: +1 724 864 9255

info.pbmvalve@imi-critical.com

IMI Critical Engineering

Lakeside, Solihull Parkway
Birmingham Business Park
Birmingham B37 7xz
United Kingdom

Tel: +44 (0)121 717 3700

Fax: +44 (0) 121 717 3701

imi-critical.com

IMI Critical
Engineering

[Breakthrough
Engineering]